

SECTION 15

COMPOSOLITE®

FIBERGLASS BUILDING PANEL SYSTEM

AND

COMPOSOLITE® HD

HEAVY DUTY BUILDING PANEL SYSTEM



Look for this blue line in the left margin of the Design Manual documents. This line shows you where the latest update has been made.

COMPOSOLITE® FIBERGLASS BUILDING PANEL SYSTEM

INTRODUCTION

COMPOSOLITE® is an patented advanced composite building panel system suitable for major load bearing structural applications. The modular construction system consists of a small number of interlocking fiber reinforced polymer (FRP) structural components produced by the pultrusion process. The main building panels are 80mm thick and either 604.3mm or 348.0mm wide and feature a cellular construction. Through the use of toggles and/or hangers, panels can be connected to one another, to 3-way connectors, or to 45° connectors.

This uniquely designed system of interlocking components makes it possible to design fiberglass structures at significantly lower costs for a broad range of construction applications.

COMPOSOLITE® structures can be designed to be shipped flat to the job site.

FEATURES

The **COMPOSOLITE®** fiberglass building panel system is comprised of pultruded FRP components. The system provides these features:

- Corrosion Resistance
- Strong
- Interlocking Joints
- Light Weight
- Non-Conductive
- Easy to Install
- Easy to Maintain
- Cost Effective

SYSTEM DESIGN

COMPOSOLITE® is a system of five interlocking components manufactured of pultruded fiberglass reinforced polymer. The system combines manufacturing simplicity with an almost unlimited number of configurations.

The **COMPOSOLITE®** panel feature integral grooves into which a toggle is inserted during assembly. 3-way and 45° connectors allow the system components to turn corners and facilitate the joining of walls or sides. For added flexibility, the system also includes a hanger and an end cap.

Joints between panels and connectors are bonded during final assembly. Adhesive is applied along the length of the panel and connector. The toggle, to which adhesive is not applied, is then inserted as an assembly aid to mechanically secure the components and create even pressure along the length of the joint until the adhesive between the structural components cures.

MATERIALS OF CONSTRUCTION

Because the system is constructed of FRP, **COMPOSOLITE®** is particularly well-suited for outdoor use and/or corrosive environments.

Standard **COMPOSOLITE®** features a polyester fire retardant resin system in a slate gray color. The standard fire retardant resin meets the flame spread requirements of Class 1 rating of 25 or less per ASTM E-84 and the self-extinguishing requirements of ASTM D-635. The resin mixture is UV inhibited and the composite includes a surface veil on all exposed surfaces for enhanced corrosion and UV protection.

Other colors and resins, including polyester, vinyl ester, and manufactured to meet NSF-61 certification for hot and cold, are available upon request.

APPLICATIONS

COMPOSOLITE® panels are designed for major load bearing structural applications. Typical applications are:

- Buildings
- Pedestrian Bridge Decks
- Platforms & Walkways
- Secondary Containment
- Bridge Enclosure Systems
- Tank Covers
- Cellular Enclosures
- Baffles

COMPOSOLITE® FIBERGLASS BUILDING PANEL SYSTEM COMPONENTS

Structural Component Mechanical Properties (minimum)

PROPERTIES	ASTM TEST METHOD	VALUE (N/mm ²)
Flexural Strength, LW	D790	168.9
Flexural Strength, CW	D790	56.5
Flexural Modulus, LW	D790	6101.9
Flexural Modulus, CW	D790	4454.0
Tensile Strength, LW	D638	214.4
Tensile Modulus, LW	D638	17140.4
Short Beam Shear, LW	D2344	22.0

Note: All values are minimum ultimate properties from coupon tests.

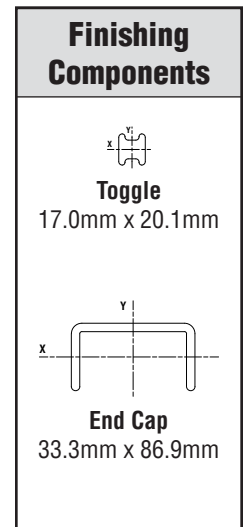
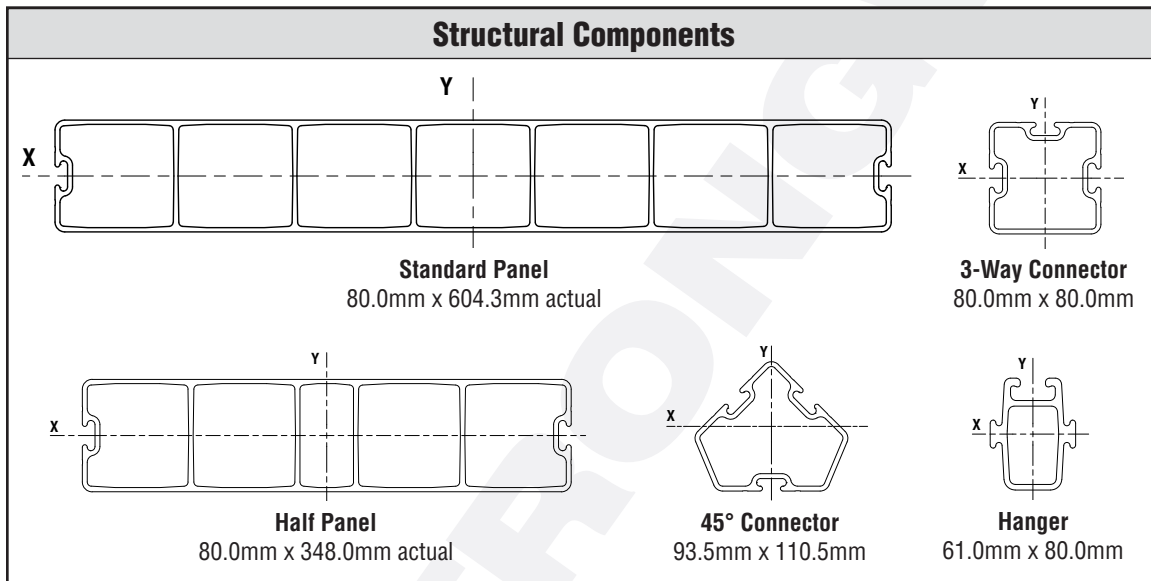

Section Properties

SHAPE	WEIGHT KG/M	I _x MM ⁴	S _x MM ³	r _x MM	I _y MM ⁴	S _y MM ³	r _y MM	A MM ²	Aw _x MM ²	Aw _y MM ²
Panel	11.19	6.82 x 10 ⁶	1.71 x 10 ⁵	33.16	2.12 x 10 ⁸	0.167 x 10 ⁶	185.00	6206	2020	4186
Half Panel	7.5	4.13 x 10 ⁶	1.03 x 10 ⁵	31.96	4.75 x 10 ⁷	2.73 x 10 ⁵	108.33	4046	1604	2442
3-Way Connector	2.53	1.08 x 10 ⁶	2.57 x 10 ⁴	28.70	1.13 x 10 ⁶	2.82 x 10 ⁴	29.41	1305	-	-
45° Connector	2.60	1.16 x 10 ⁶	2.14 x 10 ⁴	29.41	1.36 x 10 ⁶	2.45 x 10 ⁴	31.83	1337	-	-
Hanger	2.31	6.95 x 10 ⁵	1.66 x 10 ⁴	23.48	4.69 x 10 ⁵	1.54 x 10 ⁴	19.30	1260	-	-
Toggle	0.49	6.16 x 10 ³	6.16 x 10 ²	4.82	7.45 x 10 ³	8.75 x 10 ²	5.30	265	-	-
End Cap	0.89	4.37 x 10 ⁴	1.77 x 10 ⁶	9.75	4.94 x 10 ⁵	1.14 x 10 ⁴	32.78	459	-	-

COMPOSOLITE® STANDARD PANEL LOAD TABLES

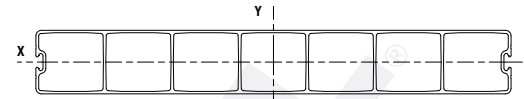

Standard Panel
80.0mm x 604.3mm actual

Uniform Load (Deflection in mm)

LOAD in kN/m²

SPAN (m)	2.0	2.5	3.0	3.5	4.0	5.0	6.0	8.0	10.0	12.0	15.0	20.0	$E_a I$ (10 ⁹ N-cm ²)	L/100 LIMITS
1.0	0.14	0.18	0.21	0.25	0.29	0.36	0.43	0.57	0.72	0.86	1.07	1.43	1.11	10
1.5	0.66	0.82	0.99	1.15	1.32	1.65	1.98	2.63	3.29	3.95	4.94	6.59	1.22	15
2.0	1.92	2.41	2.89	3.37	3.85	4.81	5.77	7.70	9.62	11.55	14.43	19.24	1.32	20
2.5	4.43	5.54	6.64	7.75	8.86	11.07	13.29	17.72	22.15				1.40	25
3.0	8.63	10.79	12.95	15.10	17.26	21.58	25.89						1.49	30
3.5	15.67	19.59	23.51	27.43	31.35								1.52	35
4.0	26.05	32.56	39.08										1.56	40
4.5	41.20												1.58	45

NOTE: The stiffness ($E_a I$) values are based on full-scale deflection testing. NOTE: Calculated deflection values end when deflection exceeds L/100, or 4.5m max span.

Concentrated Load (Deflection in mm)

LOAD in kN per METER of WIDTH

SPAN (m)	2.0	2.5	3.0	3.5	4.0	5.0	6.0	8.0	10.0	12.0	15.0	20.0	$E_a I$ (10 ⁹ N-cm ²)	L/100 LIMITS
1.0	0.23	0.29	0.34	0.40	0.46	0.57	0.69	0.92	1.14	1.37	1.72	2.29	1.11	10
1.5	0.70	0.88	1.05	1.23	1.41	1.76	2.11	2.81	3.51	4.22	5.27	7.03	1.22	15
2.0	1.54	1.92	2.31	2.69	3.08	3.85	4.62	6.16	7.70	9.24	11.55	15.39	1.32	20
2.5	2.83	3.54	4.25	4.96	5.67	7.09	8.50	11.34	14.17	17.01	21.26		1.40	25
3.0	4.60	5.75	6.90	8.05	9.21	11.51	13.81	18.41	23.01	27.62			1.49	30
3.5	7.16	8.96	10.75	12.54	14.33	17.91	21.49	28.66					1.52	35
4.0	10.42	13.03	15.63	18.24	20.84	26.05	31.26						1.56	40
4.5	14.65	18.31	21.97	25.64	29.30	36.62	43.95						1.58	45
5.0	19.97	24.96	29.95	34.94	39.94	49.92							1.59	50
5.5	26.41	33.02	39.62	46.22	52.82								1.60	55
6.0	33.87	42.33	50.80	59.27									1.62	60

NOTE: The stiffness ($E_a I$) values are based on full-scale deflection testing. NOTE: Calculated deflection values end when deflection exceeds L/100, or 6.0m max span.

COMPOSOLITE® HALF PANEL LOAD TABLES

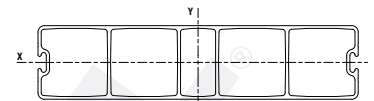

Half Panel
80.0mm x 348.0mm actual

Uniform Load (Deflection in mm)

LOAD in kN/m²

SPAN (m)	2.0	2.5	3.0	3.5	4.0	5.0	6.0	8.0	10.0	12.0	15.0	20.0	$E_a I$ (10 ⁹ N-cm ²)	L/100 LIMITS
1.0	0.18	0.23	0.27	0.32	0.36	0.45	0.54	0.72	0.90	1.08	1.35	1.80	50.2	10.00
1.5	0.91	1.14	1.37	1.60	1.83	2.28	2.74	3.65	4.57	5.48	6.85	9.14	50.2	15.00
2.0	2.89	3.61	4.33	5.05	5.77	7.22	8.66	11.55	14.44	17.32			50.2	20.00
2.5	7.05	8.81	10.57	12.34	14.10	17.62	21.15						50.2	25.00
3.0	8.53	10.66	12.79	14.92	17.05	21.32	25.58						86.1	30.00
3.5	15.80	19.74	23.69	27.64	31.59								86.1	35.00
4.0	26.95	33.68	40.42										86.1	40.00
4.5	43.16												86.1	45.00

NOTE: The stiffness ($E_a I$) values are based on full-scale deflection testing. NOTE: Calculated deflection values end when deflection exceeds L/100, or 4.5m max span.

Concentrated Load (Deflection in mm)

LOAD in kN per WIDTH of PANEL

SPAN (m)	2.0	2.5	3.0	3.5	4.0	5.0	6.0	8.0	10.0	12.0	15.0	20.0	$E_a I$ (10 ⁹ N-cm ²)	L/100 LIMITS
1.0	0.83	1.04	1.24	1.45	1.66	2.07	2.49	3.32	4.15	4.98	6.22	8.30	50.2	10.00
1.5	2.80	3.50	4.20	4.90	5.60	7.00	8.40	11.20	14.00				50.2	15.00
2.0	6.64	8.30	9.96	11.62	13.27	16.59	19.91						50.2	20.00
2.5	12.96	16.20	19.45	22.69	25.93								50.2	25.00
3.0	13.07	16.33	19.60	22.87	26.13								86.1	30.00
3.5	20.75	25.94	31.12										86.1	35.00
4.0	30.97	38.72											86.1	40.00
4.5	44.10												86.1	45.00

NOTE: The stiffness ($E_a I$) values are based on full-scale deflection testing. NOTE: Calculated deflection values end when deflection exceeds L/100, or 4.5m max span.

COMPOSOLITE® HD HEAVY DUTY BUILDING PANEL SYSTEM

INTRODUCTION

COMPOSOLITE® HD is a heavy duty advanced composite building panel system suitable for major load bearing structural applications. The modular construction system consists of a small number of interlocking fiber reinforced polymer (FRP) structural components produced by the pultrusion process. The main panel is 115mm thick x 498.5mm wide nominal size and features a cellular construction. Panels can be connected to one another through the use of the same toggles used in the standard **COMPOSOLITE®** system.

Like standard **COMPOSOLITE®** panels, **COMPOSOLITE® HD** makes it possible to design fiberglass structures at significantly lower costs for a broad range of construction applications. **COMPOSOLITE® HD** structures can be designed to be shipped flat to the job site.

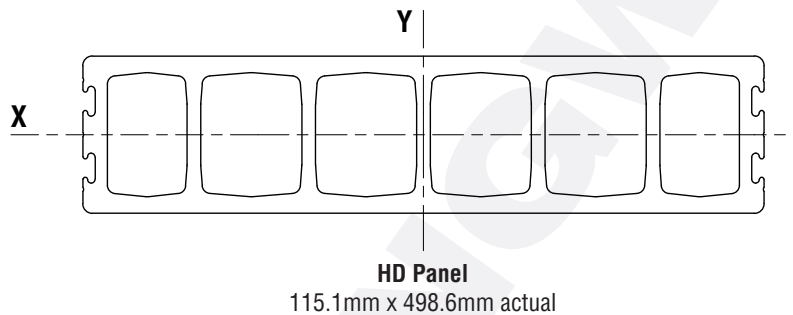

Section Properties

WEIGHT	38.95 kg/m
I_x	3.99 x 10 ⁷ mm ⁴
S_x	6.93 x 10 ⁵ mm ³
r_x	43.79 mm
I_y	4.88 x 10 ⁸ mm ⁴
S_y	1.96 x 10 ⁶ mm ³
r_y	153.18 mm
A	20798 mm ²
Aw_x	6124 mm ²
Aw_y	14674 mm ²