

SECTION 16

FIBERGLASS FLOORING AND DECKING SYSTEMS

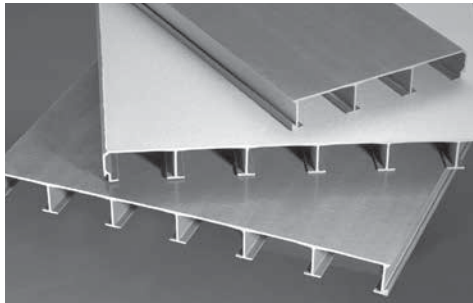

SAFPLANK®
FIBERGLASS PLANK SYSTEM



SAFPLANK HD®
HEAVY DUTY DECKING SYSTEM

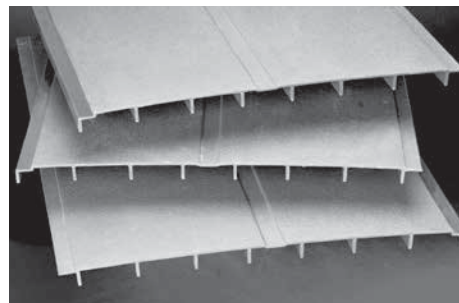

SAFDECK®
FIBERGLASS DECKING SYSTEM

Look for this blue line in the left margin of the Design Manual documents. This line indicates where the latest update has been made.

SAFPLANK® FIBERGLASS PLANK SYSTEM

INTRODUCTION

SAFPLANK® is a high strength plank system of fiberglass panels designed to interconnect for a continuous solid surface. **SAFPLANK®** is intended to replace wood, aluminum or steel planks in environments where corrosion or rotting creates costly maintenance problems or unsafe conditions. Non-conductive and non-sparking, **SAFPLANK®** provides safe walkways in electrical applications.

FEATURES

The **SAFPLANK®** fiberglass plank system is comprised of pultruded FRP panels. The system provides these features:

- Corrosion Resistant
- Strong
- Lightweight
- Easy to Install
- Easy to Maintain
- Non-Sparking
- Easily Transported
- Low Conductivity

SIZES

SAFPLANK® is available in 2" deep planks in both 12" and 24" widths to offer flexibility in design. Stock panels are available in 20' and 24' lengths. Other lengths are available upon request. **SAFPLANK®** may be ordered with a grit surface or with a smooth surface for non-pedestrian applications.

MATERIALS OF CONSTRUCTION

SAFPLANK® is a composite of fiberglass reinforcements (glass and mat) and a thermoset resin system. The panels are produced by the pultrusion process. Planks will be manufactured using polyester resin to ANSI/NSF standard 61 certified for potable water applications, if required.

The standard resin system is a slate gray fire retardant polyester resin meeting the requirements of Class 1 flame spread rating of 25 or less per ASTM E-84 and the self-extinguishing requirements of ASTM D-635. The resin is UV inhibited and the composite includes a surface veil on all exposed surfaces for enhanced corrosion and UV protection. Other resins and colors are available upon request.

The standard grit system for **SAFPLANK®** is a polyurethane based medium grit. This grit system is recommended for light pedestrian traffic only. Other grit systems available include epoxy medium and epoxy coarse and may be more appropriate for applications with heavier traffic.

APPLICATIONS

SAFPLANK® is designed to be used for flooring and covers. Typical applications include:

- Cooling Tower Decking
- Odor Control Covers
- Roofing Walkways
- Temporary Flooring
- Access Walkways
- Cellular Wall Panels

SAFPLANK®, when turned upside down, serves as an excellent stay-in-place concrete forming system in applications where corrosion and weight are construction concerns. Polyester resin is acceptable when pultruded FRP shapes are used as a stay in place (SIP) form. For concrete installations where long-term structural integrity is required, vinyl ester resin should be used.

SAFPLANK® FIBERGLASS PLANK SYSTEM

Two hold-down connections are available for installing SAFPLANK®. Both hold-downs can be used with either 12" or 24" wide SAFPLANK®.

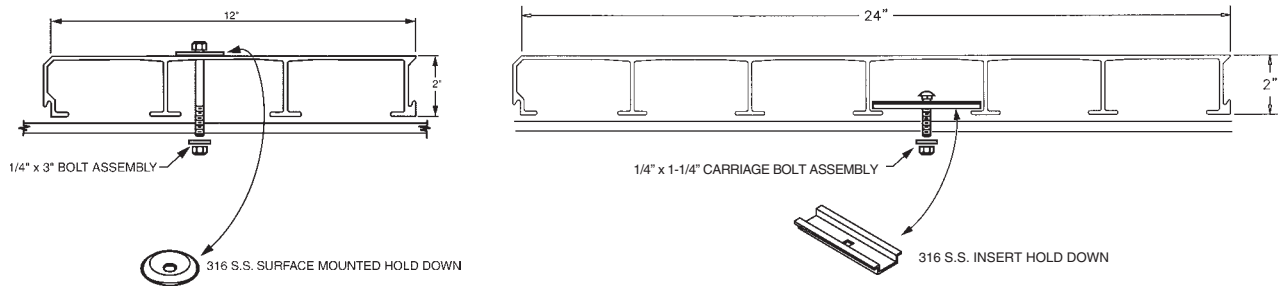

UNIFORM LOAD (Deflection in inches)

LOAD in LB / SQUARE FOOT (PSF)

SPAN	PLANK ORIENTATION	12" SAFPLANK® $I_{12} = 1.69 \text{ in.}^4$, wt = 2.6 lb / lin. ft. (gritted)						24" SAFPLANK® $I_{24} = 3.01 \text{ in.}^4$, wt = 5.1 lb / lin. ft. (gritted)				
		50	100	200	300	500	1000	100	200	300	500	1000
24"	REGULAR	0.006	0.011	0.023	0.034	0.057	0.113	0.015	0.030	0.045	0.075	0.151
	INVERTED	0.007	0.014	0.026	0.040	0.062		0.017	0.030	0.054	0.086	0.161
36"	REGULAR	0.022	0.043	0.087	0.130	0.217		0.046	0.092	0.138	0.231	
	INVERTED	0.024	0.046	0.089	0.121			0.051	0.109	0.161	0.261	
48"	REGULAR	0.062	0.123	0.247	0.370			0.133	0.265	0.398		
	INVERTED	0.064	0.120	0.237				0.130	0.287	0.414		
60"	REGULAR	0.140	0.281	0.562				0.302	0.605			
	INVERTED	0.138	0.266					0.286	0.634			
72"	REGULAR	0.291	0.583					0.627				
	INVERTED	0.268						0.622				

CONCENTRATED LOAD (Deflection in inches)

LOAD in LB / FOOT of WIDTH

SPAN	PLANK ORIENTATION	12" SAFPLANK® $I_{12} = 1.69 \text{ in.}^4$, wt = 2.6 lb / lin. ft. (gritted)						24" SAFPLANK® $I_{24} = 3.01 \text{ in.}^4$, wt = 5.1 lb / lin. ft. (gritted)				
		50	100	200	300	500	1000	100	200	300	500	1000
24"	REGULAR	< 0.005	0.009	0.018	0.027	0.045	0.091	0.012	0.024	0.036	0.060	0.121
	INVERTED	0.006	0.011	0.023	0.033	0.053	0.099	0.014	0.026	0.039	0.068	0.138
36"	REGULAR	0.012	0.023	0.046	0.070	0.116	0.232	0.024	0.049	0.074	0.123	0.246
	INVERTED	0.013	0.026	0.050	0.074	0.118	0.233	0.030	0.055	0.080	0.130	0.287
48"	REGULAR	0.025	0.049	0.099	0.148	0.247	0.494	0.053	0.106	0.159	0.265	
	INVERTED	0.029	0.053	0.102	0.148	0.239	0.469	0.055	0.106	0.157	0.259	
60"	REGULAR	0.045	0.090	0.180	0.270	0.450		0.097	0.193	0.290	0.484	
	INVERTED	0.047	0.088	0.175	0.258	0.426		0.095	0.186	0.278	0.457	
72"	REGULAR	0.078	0.155	0.311	0.466			0.167	0.334	0.501		
	INVERTED	0.079	0.150	0.289	0.430			0.150	0.298	0.442	0.740	

Maximum deflections shown are based on a deflection of approximately $L/100$. To calculate the maximum deflection for a simply supported continuous beam spanning two equal lengths with the uniform or concentrated load on one span only, multiply the above deflections by 0.71. For ventilated SAFPLANK®, divide deflection values by .95.

Polyester resin is acceptable when pultruded FRP shapes are used as a stay in place (SIP) form. For concrete installations where long-term structural integrity is required, vinyl ester resin should be used. SAFPLANK® joints have been tested for 300 lbs concentrated point load applied over 4 in.² area (See ASCE 7 - Minimum Design Loads for Buildings and other Structures). For 24" span, a 300 lb concentrated load has a factor of safety (FS) of 6, a 36" span has an FS of 4 and a 48" span has an FS of 3. Spans should be limited to 48" for this type of loading.

SAFPLANK HD® HEAVY DUTY DECKING SYSTEM

INTRODUCTION

SAFPLANK HD® is a high strength system of fiberglass planks designed to form a continuous solid surface. **SAFPLANK HD®** is intended to replace wood, aluminum or steel planks in environments where corrosion or rotting creates costly maintenance problems or unsafe conditions.

FEATURES

The **SAFPLANK HD®** fiberglass plank system is comprised of pultruded FRP panels. The system provides these features:

- Corrosion Resistant
- Strong
- Lightweight
- Easy to Install
- Easy to Maintain
- Non-Sparking
- Low Conductivity

SIZES

SAFPLANK HD® is available in 6" deep panels in 36" width. Stock panels are available in 20' and 24' lengths. Other lengths are available upon request. **SAFPLANK HD®** may be ordered with a grit surface or with a smooth surface for non-pedestrian applications.

MATERIALS OF CONSTRUCTION

SAFPLANK HD® is a composite of fiberglass reinforcements (glass roving and continuous filament mat) and a thermoset resin system. The pultrusion process is used to produce the panels. Planks can be manufactured using polyester resin to ANSI/NSF standard 61 certified for potable water applications, if required.

The standard resin system is a slate gray fire retardant polyester resin meeting the requirements of Class 1 flame spread rating of 25 or less per ASTM E-84 and the self-extinguishing requirements of ASTM D-635. The resin is UV inhibited and the composite incorporates a surface veil on all exposed surfaces for enhanced corrosion and UV protection. Other resins and colors are available upon request.

The standard grit system for **SAFPLANK HD®** is a polyurethane based medium grit. This grit system is recommended for light pedestrian traffic only. Other grit systems available include epoxy medium and epoxy coarse and may be more appropriate for applications with heavier traffic.

APPLICATIONS

SAFPLANK HD® is designed to be used for numerous applications including:

- Temporary Flooring
- Windwalls
- Roofing Walkways
- Concrete Forming Systems
- Odor Control Covers
- Dock Surfacing
- Cellular Wall Panels

SAFPLANK HD® HEAVY DUTY DECKING SYSTEM

SAFPLANK HD® Mechanical Properties

UNIFORM LOAD (Deflection in inches)

LOAD in LB / SQUARE FOOT (PSF)

I = 129.8 in⁴, A = 25.0 in², wt = 21.0 lb / lin. ft

SPAN (ft)	40		60		80		100	
	Deflection (in)	L/Ratio	Deflection (in)	L/Ratio	Deflection (in)	L/Ratio	Deflection (in)	L/Ratio
10	0.07	1731	0.10	1154	0.14	865	0.17	692
12	0.14	1002	0.22	668	0.29	501	0.36	401
14	0.27	631	0.40	420	0.53	315	0.67	252
16	0.45	423	0.68	282	0.91	211	1.14	169
18	0.73	297	1.09	198	1.46	148		
20	1.11	216						
22	1.62	163						

CONCENTRATED LINE LOAD (Deflection in inches)

LOAD in LB / FOOT of WIDTH

I = 129.8 in⁴, A = 25.0 in², wt = 21.0 lb / lin. ft

SPAN (ft)	100		300		600	
	Deflection (in)	L/Ratio	Deflection (in)	L/Ratio	Deflection (in)	L/Ratio
10	0.03	4327	0.08	1442	0.17	721
12	0.05	3005	0.14	1002	0.29	501
14	0.08	2207	0.23	736	0.46	368
16	0.11	1690	0.34	563	0.68	282
18	0.16	1335	0.49	445	0.97	223
20	0.22	1082	0.67	361	1.33	180
22	0.30	894	0.89	298		

Notes:

Contact Strongwell for higher load conditions than what is tabulated.

Values are limited to deflection ratios less than L/150 or a maximum span of 22 feet.

Material Property Data:

Full Section Modulus of Elasticity = 3,000,000 psi (minimum)

Coefficient of Thermal Expansion (LW) = 4.7×10^{-6} in/in/°F

Coefficient of Thermal Expansion (CW) = 13.9×10^{-6} in/in/°F

EXTREN® Minimum Material Strength Properties for Lengthwise and Crosswise Directions

SAFPLANK HD® HEAVY DUTY DECKING SYSTEM

Two hold-down connections are available for installing SAFPLANK HD®.

ANCHOR & ANGLE

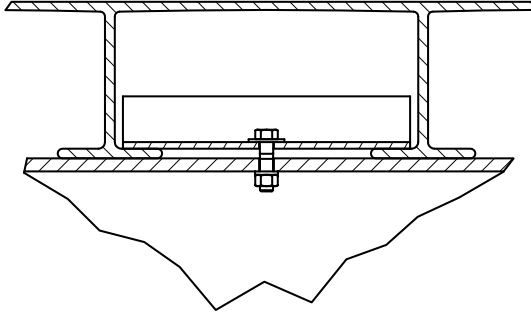

ANCHOR BOLT ONLY

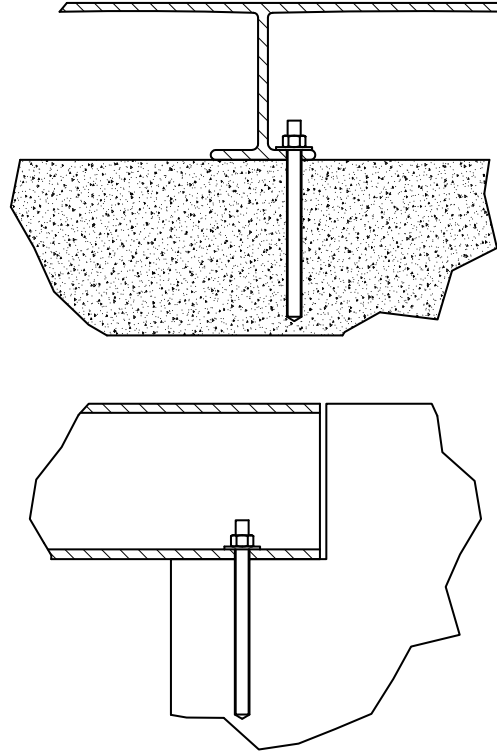

SAFDECK® FIBERGLASS DECKING SYSTEM

INTRODUCTION

SAFDECK® is a system of 24" wide fiberglass panels designed to overlap for a continuous solid surface. **SAFDECK®** is intended to replace wood, aluminum or steel decking in environments where corrosion or rotting creates costly maintenance problems or unsafe conditions. Non-conductive and non-sparking, **SAFDECK®** provides safe walkways in electrical applications.

FEATURES

The **SAFDECK®** fiberglass decking system is comprised of pultruded FRP panels. The system provides these features:

- Corrosion Resistant
- Strong
- Lightweight
- Easy to Install
- Easy to Maintain
- Non-Sparking
- Easily Transported
- Low Conductivity

SIZES

SAFDECK® is available in 1-1/8" deep planks in 24" widths. The decking system is designed to be a one-for-one replacement for plywood and has a 60-pound per square foot rating at 3-foot spans with less than L/180 deflection. All panels are gritted and are available in 24' lengths. Other lengths are available upon request. **SAFDECK®** may be ordered with a smooth surface for non-pedestrian applications.

MATERIALS OF CONSTRUCTION

SAFDECK® is a high strength, one-piece, overlapping panel system. Manufactured of pultruded fiberglass reinforced polymer (FRP), **SAFDECK®** is particularly well suited to corrosive environments.

The standard resin system is a slate gray fire retardant polyester resin meeting the requirements of Class 1 flame spread rating of 25 or less per ASTM E-84 and the self-extinguishing requirements of ASTM D-635. The resin is UV inhibited and the composite includes a surface veil on all exposed surfaces for enhanced corrosion and UV protection. Other resins and colors are available upon request.

The standard grit system for **SAFDECK®** is a polyurethane based medium grit. This grit system is recommended for light pedestrian traffic only. Other grit systems available include epoxy medium and epoxy coarse and may be more appropriate for applications with heavier traffic.

APPLICATIONS

SAFDECK® is designed to be used for flooring and covers. Typical applications include:

- Cooling Tower Decking
- Odor Control Covers
- Roofing Walkways
- Temporary Flooring
- Wind Walls
- Cellular Wall Panels

SAFDECK® FIBERGLASS DECKING SYSTEM

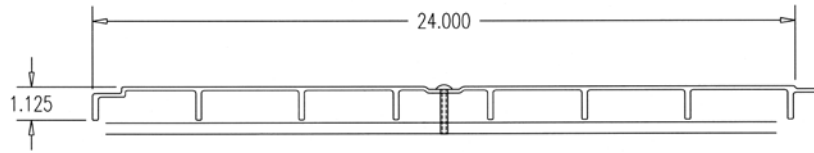

SAFDECK® LOAD / DEFLECTION DATA

UNIFORM LOAD (Deflection in inches)

LOAD in LB / SQUARE FOOT (PSF)
 $I_{12} = 0.439 \text{ in.}^4$, wt = 4.1 lb / lin. ft. (gritted)

SPAN	25	50	60	75	100	200	300
24"	0.015	0.030	0.036	0.044	0.059	0.119	0.179
36"	0.063	0.126	0.151	0.189	0.252		
48"	0.215	0.430					

CONCENTRATED LOAD (Deflection in inches)

LOAD in LB / FOOT of WIDTH
 $I_{12} = 0.439 \text{ in.}^4$, wt = 4.1 lb / lin. ft. (gritted)

SPAN	25	50	60	75	100	200	300
24"	0.012	0.023	0.029	0.036	0.048	0.096	0.143
36"	0.032	0.064	0.081	0.101	0.134	0.269	
48"	0.073	0.147	0.206	0.257	0.343		

Maximum deflections shown are based on a deflection of approximately L/100. To calculate the maximum deflection for a simply supported continuous beam spanning two equal lengths with the uniform or concentrated load on one span only, multiply the above deflections by 0.71.