

SECTION 6 - ELEMENTS OF SECTIONS

Table of Contents

Symbols for Elements of Sections.....	6-2
Introduction	6-3
Large EXTREN® Structural Shapes.....	6-3
Double Web Beams.....	6-3

Tables

EXTREN® W-Shapes.....	6-4	F Section	6-16
EXTREN® I-Shapes	6-5	Z-Section	6-16
EXTREN® Channels	6-6	Kick Plates.....	6-17
EXTREN® Equal Leg Angles	6-7	Square Tube / Round Hole.....	6-17
Structural Tees (Cut from EXTREN® W & I-Shapes).....	6-8	Struts & Double Struts.....	6-18
Double EXTREN® Channels.....	6-9	Flight Channel	6-19
Double Angles / EXTREN® Equal Leg Angles.....	6-10	Curb Angles.....	6-20
EXTREN® Round Tubes	6-11	Slide Guide	6-20
EXTREN® Square Tubes.....	6-12	SAFRAIL™ Square Post or Rail Section	6-21
EXTREN® Rectangular Shapes.....	6-13	SAFRAIL™ Round Post or Rail Section	6-21
Square Bars.....	6-14	Half Round Rail Section	6-21
Round Rod	6-14		
Flat Strip	6-15		
Unequal Leg Angle.....	6-15		

SECTION 6

ELEMENTS OF SECTIONS



Look for this blue line in the left margin of the Design Manual documents. This line shows you where the latest update has been made.

SYMBOLS FOR ELEMENTS OF SECTIONS

A	Cross-sectional area (mm ²)
A_w	Cross-sectional area of web or webs (mm ²)
D	Outside diameter of round tube (mm) Diameter of round rod (mm) Diameter of round hole in square tube (mm)
I	Moment of Inertia (mm ⁴)
J	Torsional constant (mm ⁴)
R	Radius (mm)
R_f	Flange toe radius (mm)
R_i	Radius of inside corner (mm)
R_o	Radius of outside corner (mm)
S	Section modulus (mm ³)
S_b	Section modulus from the bottom of an unsymmetrical section (mm ³)
S_t	Section modulus from the top of an unsymmetrical section (mm ³)
Wt	Weight of section (kg)
b	Width of section (mm) Outside dimension of square tube or bar (mm)
b_f	Width of flange (mm)
b₁	Width between flange section in strut (mm) Top width of hat section (mm)
d	Full depth of section (mm)
d₁	Outer depth of shape in F section (mm)
r	Radius of gyration (mm)
s	Spacing between back to back channels or angles (mm)
t	Thickness of section (mm) Wall thickness of tubes (mm)
t_b	Thickness of width dimension (mm)
t_d	Thickness of depth dimension (mm)
t_f	Thickness of flange (mm)
t_w	Thickness of web (mm)
x	Distance from the outside of the web to the minor (Y-Y) axis of a channel section or other similar unsymmetrical sections (mm)
y	Distance from neutral X-X axis to the outer-most fibers of a cross section (in) Distance from the back of the flange to the major (X-X) axis of a tee section or other similar unsymmetrical sections (mm)

ELEMENTS OF SECTIONS

INTRODUCTION

The values shown in the following tables have been computed from the nominal dimensions of the shapes.

The tables are arranged in ascending order of sizes with values tabulated for quick reference when selecting members for design requirements. Note that section properties are given for both “strong” (X-X), and “weak” (Y-Y) axis for the nonsymmetrical shapes.

Some shapes may not be stocked at all times as regular inventory items so the designer should consult the **Availability List** before selecting a specific size for an application.

LARGE EXTREN® STRUCTURAL SHAPES

457mm AND 610mm EXTREN® FIBERGLASS I-SHAPES

457mm and 610mm **EXTREN®** I-Shapes are the largest standard structural shapes pultruded. Their design properties will allow the engineer to design larger all-composite structures, spanning greater distances than were ever possible with standard pultruded fiberglass structural shapes.

As shown in the **ELEMENTS OF SECTION** tables, an **EXTREN®** 610mm I-beam has a moment of inertia of $792 \text{ mm}^4 \times 10^6$, more than four times as stiff as the **EXTREN®** 305mm x 305mm x 12.7mm W-shape. This means that for longer spans when shear deflections are negligible, I-610 will carry the same load as a W-305 at any given span and produce about 1/4 the deflection. Or stated another way, when shear deflection is negligible, an I-610 can carry four times the load of a W-305 and produce about the same deflection.

EXTREN® 457mm and 610mm I-shapes, with their unique thick flange construction, assure the engineer that stress will not normally control the design when the compression flange is adequately laterally supported. Other sections in this chapter offer suggestions for effective lateral bracing systems.

The designer is also cautioned that it may be necessary to add stiffeners between the flanges at points of concentrated loads and at supports. This is referenced in Section 8 — **FLEXURAL MEMBERS (BEAMS)** of the Strongwell *Design Manual*.

DOUBLE WEB BEAMS

203mm AND 914mm EXTREN DWB®

Strongwell produces two sizes of double web I-beams, an 203mm x 152mm DWB and a 914mm x 457mm DWB. They are each offered in “all glass” or “hybrid” forms (hybrid refers to the combination of the dual carbon and glass reinforcements).

The carbon/glass hybrid beam has a flexural modulus of elasticity that is approximately $41.4 \times 10^3 \text{ N/mm}^2$, compared to that of a standard **EXTREN®** wide flange which ranges between 17.9 to $19.3 \times 10^3 \text{ N/mm}^2$.

Additionally, the double web shape has significantly improved the torsional stability of the beam under load. This increased stability is very significant and reduces the beams need for lateral bracing.

Section 17 — **EXTREN DWB® DESIGN GUIDE** is devoted to design information from the 203mm x 152mm shape and the 914mm x 457mm shape.

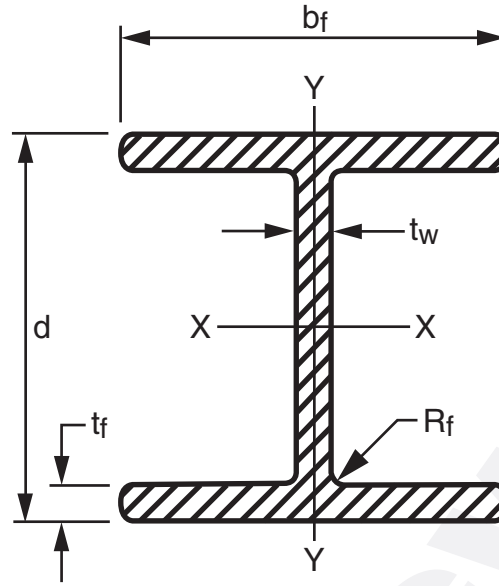

EXTREN® W-SHAPES

PHYSICAL PROPERTIES							SECTION PROPERTIES						DESIGN PROPERTIES		
SIZE				A	NOM. Wt/m	R_f	AXIS X—X			AXIS Y—Y			$\frac{b_f}{t_f}$	A_w	J
d	b_f	t_w	t_f				I	S	r	I	S	r			
mm	mm	mm	mm	mm ²	kg	mm	mm ⁴ x10 ⁶	mm ³ x10 ³	mm	mm ⁴ x10 ⁶	mm ³ x10 ³	mm	mm ²	mm ⁴ x10 ⁶	
50.8	50.8	3.18	3.18	465	0.774	1.59	0.208	8.19	12.2	0.071	2.79	12.2	16.00	142	0.002
76.2	76.2	6.35	6.35	1374	2.51	3.18	1.32	34.6	31.0	0.470	12.3	18.5	12.00	406	0.018
102	102	6.35	6.35	1865	3.30	3.18	3.30	65.1	42.2	1.11	22.0	24.6	16.00	568	0.025
152	152	6.35	6.35	2832	5.24	3.18	11.8	155	64.5	3.75	49.2	36.6	24.00	890	0.038
152	152	9.53	9.53	4181	7.63	4.76	16.7	220	63.5	5.63	73.7	36.8	16.00	1271	0.126
203	203	9.53	9.53	5632	10.4	4.76	41.3	406	85.9	13.3	131	48.8	21.33	1755	0.17
203	203	12.7	12.7	7426	13.7	6.35	52.9	520	84.6	17.8	175	49.0	16.00	2258	0.399
254	254	9.53	9.53	7084	13.1	6.35	82.8	651	108	26.0	205	60.7	26.67	2239	0.214
254	254	12.7	12.7	9387	17.3	6.35	107	839	107	34.7	273	61.0	20.00	2903	0.503
305	305	12.7	12.7	11297	20.8	6.35	188	1237	129	60.0	393	73.2	24.00	3548	0.607

NOTE: Radius dimensions listed above are for reference only. If measurements are critical, please contact Strongwell.

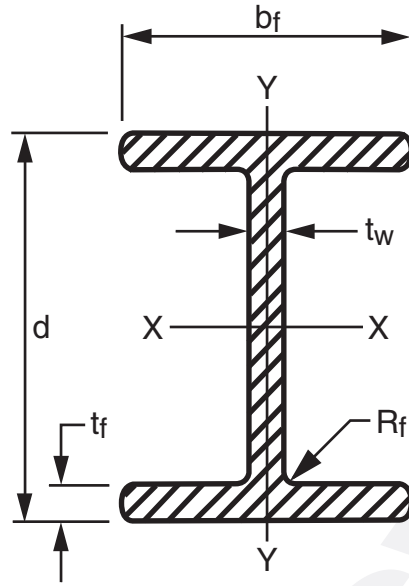

EXTREN® I-SHAPES

PHYSICAL PROPERTIES							SECTION PROPERTIES						DESIGN PROPERTIES		
SIZE				A	NOM. Wt/m	R_f	AXIS X—X			AXIS Y—Y			$\frac{b_f}{t_f}$	A_w	J
d	b_f	t_w	t_f				I	S	r	I	S	r			
mm	mm	mm	mm	mm ²	kg	mm	mm ⁴ x10 ⁶	mm ³ x10 ³	mm	mm ⁴ x10 ⁶	mm ³ x10 ³	mm	mm ²	mm ⁴ x10 ⁶	
50.8	25.4	3.18	3.18	303	0.506	1.59	0.117	4.59	19.6	0.008	0.655	5.33	8.00	142	0.001
76.2	38.1	6.35	6.35	890	1.65	3.18	0.728	19.2	28.7	0.058	3.11	8.13	6.00	406	0.012
102	50.8	6.35	6.35	1219	2.20	3.18	1.83	36.1	39.1	0.142	5.57	10.9	8.00	568	0.016
140	63.5	6.35	6.35	1600	2.90	3.18	4.62	66.2	53.8	0.258	8.19	12.7	6.00	806	0.023
152	76.2	6.35	6.35	1858	3.44	3.18	6.63	87.2	59.9	0.470	12.5	16.0	12.00	890	0.025
152	76.2	9.53	9.53	2729	5.04	4.76	9.28	122	58.7	0.712	18.7	16.3	8.00	1271	0.082
152	102	6.35	6.35	2213	4.11	6.35	8.49	111	62.0	1.12	22.0	22.4	16.0	890	0.029
203	102	9.53	9.53	3697	6.86	4.76	23.1	227	79.2	1.68	33.1	21.3	10.67	1755	0.112
203	102	12.7	12.7	4845	8.97	6.35	29.4	289	78.2	2.25	44.4	21.6	8.00	2258	0.26
254	127	9.53	9.53	4665	8.60	4.76	46.5	366	99.8	3.27	51.5	26.4	13.33	2239	0.141
254	127	12.7	12.7	6135	11.3	6.35	59.7	470	99.1	4.37	69.2	26.9	10.00	2903	0.328
305	152	12.7	12.7	7426	13.8	6.35	106	693	119	7.54	99.1	32.0	12.00	3548	0.399
457	114	9.53	12.7	7155	12.4	12.7	214	934	173	3.19	55.9	21.1	9.00	4116	0.281
610	191	9.53	19.1	12839	24.0	12.7	792	2599	249	22	231	41.4	10.00	5439	1.04

NOTE: Radius dimensions listed above are for reference only. If measurements are critical, please contact Strongwell.

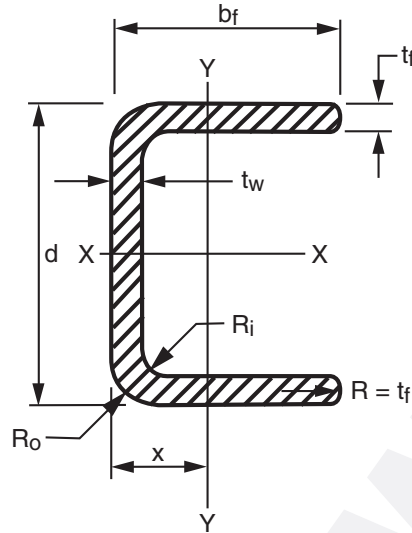

EXTREN® CHANNELS

PHYSICAL PROPERTIES						SECTION PROPERTIES								DESIGN PROPERTIES			
SIZE				A	NOM. Wt/ft	R _i	R _o	AXIS X—X			AXIS Y—Y				b _f / t _f	A _w	J
d	b _f	t _w	t _f					I	S	r	I	S	r	x			
mm	mm	mm	mm	mm ²	kg	mm	mm	mm ⁴ ×10 ⁶	mm ³ ×10 ³	mm	mm ⁴ ×10 ⁶	mm ³ ×10 ³	mm	mm	mm ²	mm ⁴ ×10 ⁶	
38.1	25.4	4.76	4.76	381	0.685	3.18	7.94	0.075	3.93	14.2	0.017	0.983	6.60	8.89	5.33	135	0.004
38.1	38.1	6.35	6.35	645	1.12	3.18	9.53	0.133	6.88	14.2	0.058	2.62	9.65	15.0	6.00	161	0.008
50.8	14.3	3.18	3.18	219	0.387	1.59	4.76	0.075	2.95	18.0	0.004	0.33	3.81	3.81	4.50	142	0.000
50.8	22.2	6.35	6.35	516	0.967	3.18	3.18	0.170	6.55	17.8	0.012	2.13	5.33	6.61	3.50	245	0.007
66.7	31.8	3.18	4.76	484	0.923	3.18	4.76	0.341	10.2	26.4	0.050	2.29	10.2	10.7	6.67	181	0.003
76.2	22.2	6.35	6.35	645	1.15	3.18	9.53	0.479	12.6	26.4	0.025	1.47	5.84	6.35	3.50	400	0.008
76.2	25.4	4.76	4.76	561	1.01	3.18	7.94	0.429	11.1	27.7	0.029	1.47	7.11	6.86	5.33	316	0.004
76.2	38.1	6.35	6.35	845	1.56	3.18	9.53	0.753	19.8	30.0	0.104	8.69	11.1	11.9	6.00	406	0.011
88.9	38.1	4.76	4.76	716	1.31	3.18	7.94	0.795	17.9	33.3	0.078	2.87	10.4	10.8	8.00	378	0.005
102	27.0	3.18	3.18	458	0.863	3.18	6.35	0.645	12.8	36.8	0.004	1.31	7.37	5.84	8.50	303	0.002
102	28.6	6.35	6.35	890	1.65	3.18	9.53	1.19	23.4	35.8	0.054	2.46	7.62	7.62	4.50	568	0.012
102	34.9	4.76	4.76	748	1.40	3.18	7.94	1.09	21.5	37.6	0.079	2.95	10.2	8.89	7.33	439	0.006
127	34.9	6.35	6.35	1135	2.08	3.18	9.53	2.41	37.9	45.5	0.104	3.93	9.40	8.64	5.50	723	0.017
140	38.1	4.76	4.76	958	1.77	3.18	7.94	2.42	34.6	50.3	0.092	3.11	9.65	8.66	8.00	619	0.007
140	38.1	6.35	6.35	1290	2.31	3.18	7.94	3.24	46.4	50.1	0.137	4.75	10.4	9.14	6.00	806	0.017
152	41.3	6.35	6.35	1374	2.50	3.18	9.53	4.25	55.9	54.9	0.179	5.74	11.2	9.65	6.50	890	0.021
152	42.9	9.53	9.53	2084	3.66	4.76	14.3	6.06	79.5	53.8	0.225	7.21	10.4	11.2	4.50	1271	0.062
203	55.6	6.35	6.35	1916	3.45	3.18	9.53	10.5	103	73.9	0.458	10.7	15.5	12.4	8.75	1213	0.025
203	55.6	9.53	9.53	2813	5.07	4.76	14.3	14.9	147	72.9	0.591	14.1	14.5	13.5	5.83	1755	0.083
254	69.8	12.7	12.7	4677	8.18	9.53	19.1	38.5	303	90.7	1.66	31.6	18.8	17.3	5.50	2903	0.250
305	76.2	12.7	12.7	5270	9.37	9.53	22.2	59.4	390	106	2.11	36.1	20.1	17.8	6.00	3548	0.312
356	88.9	19.1	19.1	9432	16.7	9.53	28.6	147	826	125	5.06	75.7	23.1	22.1	4.67	6052	1.14
457	55.6	4.76	4.76	2671	5.77	1.59	6.35	62.9	275	153	0.437	9.01	13.5	7.37	11.7	2135	0.020
610	76.0	6.35	6.35	4903	2.65	9.53	3.18	201.6	661.4	202.7	1.482	21.96	17.3	8.89	12.0	3935	0.072

NOTE: Radius dimensions listed above are for reference only. If measurements are critical, please contact Strongwell.

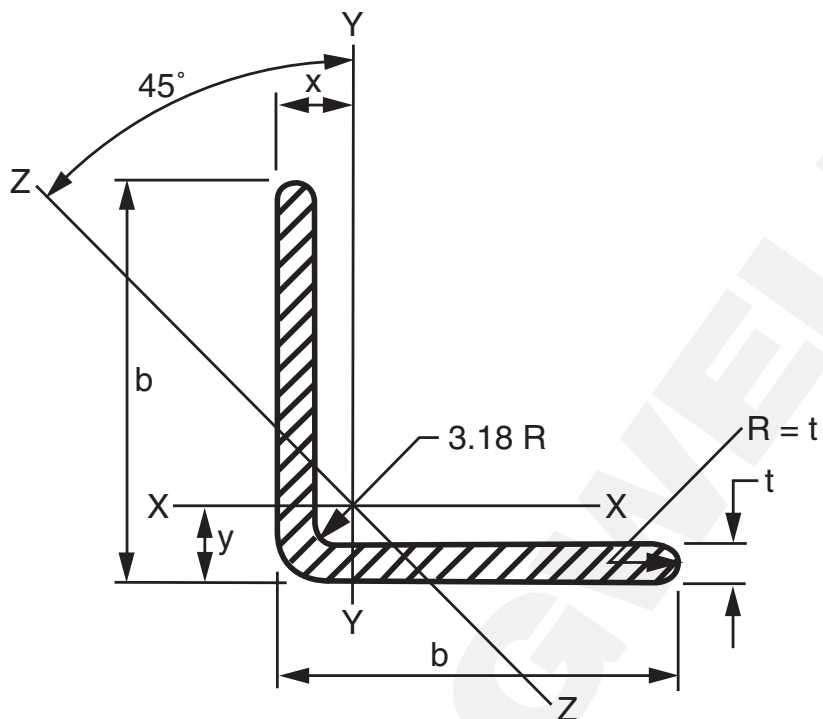

EXTREN® EQUAL LEG ANGLES

PHYSICAL PROPERTIES				SECTION PROPERTIES						DESIGN PROPERTIES	
SIZE		A	NOM. Wt/ft	AXIS X—X OR Y—Y				AXIS Z—Z		$\frac{b}{t}$	J
b	t			I	S	r	x or y	I	r		
mm	mm	mm ²	kg	mm ⁴ x10 ⁶	mm ³ x10 ³	mm	mm	mm ⁴ x10 ⁶	mm	mm ⁴ x10 ⁶	
25.4	3.18	142	0.253	0.008	0.492	7.62	7.37	0.004	4.83	8.00	0.0004
31.8	3.18	187	0.327	0.017	0.819	9.40	8.89	0.008	6.10	10.00	0.001
31.8	4.76	271	0.521	0.025	1.15	9.40	9.40	0.012	6.10	6.67	0.002
38.1	3.18	226	0.417	0.029	1.15	11.4	10.4	0.012	7.37	12.00	0.001
38.1	4.76	329	0.61	0.046	1.64	11.4	11.2	0.017	7.37	8.00	0.002
38.1	6.35	432	0.744	0.054	2.13	11.2	11.7	0.025	7.37	6.00	0.003
50.8	3.18	310	0.551	0.079	2.13	16.0	14.0	0.033	11.7	16.00	0.001
50.8	4.76	452	0.833	0.112	3.11	15.5	14.2	0.046	9.91	10.67	0.003
50.8	6.35	594	1.09	0.142	3.93	15.2	14.7	0.058	9.91	8.00	0.008
76.2	6.35	916	1.68	0.491	8.85	23.1	20.8	0.204	14.7	12.00	0.012
76.2	9.53	1348	2.47	0.708	13.1	22.9	22.1	0.291	14.7	8.00	0.037
102	6.35	1239	2.29	1.22	16.4	31.2	27.2	0.504	20.1	16.00	0.017
102	9.53	1832	3.44	1.77	24.3	31.0	28.4	0.728	19.8	10.67	0.056
102	12.7	2419	4.26	2.31	32.3	31.0	30.0	0.953	19.8	8.00	0.130
127	12.7	3039	10.00	4.72	54.9	39.4	40.9	2.03	25.9	10.00	0.016
152	6.35	1897	3.50	4.45	39.8	48.5	40.4	1.81	31.0	24.00	0.025
152	9.53	2800	5.12	6.18	55.4	47.0	40.6	2.53	30.0	16.00	0.085
152	12.7	3690	6.91	8.07	73.1	46.7	42.2	3.30	29.7	12.00	0.200

NOTE: Radius dimensions listed above are for reference only. If measurements are critical, please contact Strongwell.

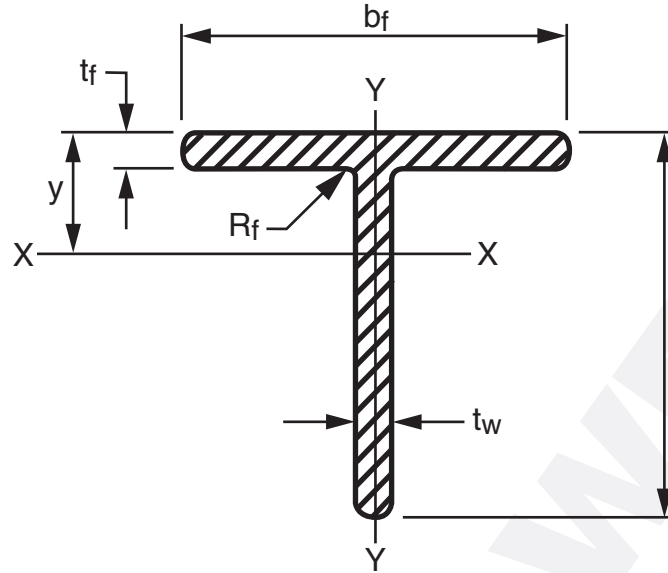

STRUCTURAL TEES
CUT FROM EXTREN® W-SHAPES

PHYSICAL PROPERTIES							SECTION PROPERTIES									DESIGN PROPERTIES		
SIZE				A	NOM. Wt/ft	R _f	I	AXIS X—X OR Y—Y				AXIS Z—Z			b _f / t _f	A _w	J	
d	b _f	t _w	t _f					S _x	S _y	r	y	I	S	r				
mm	mm	mm	mm	mm ²	kg	mm	mm ⁴ ×10 ⁶	mm ³ ×10 ³	mm ³ ×10 ³	mm	mm	mm ⁴ ×10 ⁶	mm ³ ×10 ³	mm	mm ²	mm ⁴ ×10 ⁶		
38.1	76.2	6.35	6.35	684	1.26	6.35	0.071	7.87	2.46	10.2	8.89	0.233	6.06	18.5	12.00	200	0.009	
50.8	102	6.35	6.35	929	1.65	6.35	0.175	16.1	4.42	13.7	10.9	0.558	11.0	24.4	16.00	284	0.012	
76.2	152	6.35	6.35	1413	2.62	6.35	0.624	123	10.2	21.1	15.2	1.87	24.6	36.3	24.00	445	0.018	
76.2	152	9.53	9.53	2090	3.82	9.53	0.887	54.6	14.7	20.6	16.3	2.81	36.9	36.6	16.00	632	0.060	
102	203	9.53	9.53	2813	5.19	9.53	2.19	107	27.0	27.9	20.6	6.66	65.5	48.8	21.33	877	0.082	
102	203	12.7	12.7	3716	6.88	12.7	2.81	128	35.1	27.4	21.8	8.89	87.5	49.0	16.00	1129	0.191	
127	254	9.53	9.53	3535	6.53	9.53	4.39	176	42.9	35.3	24.9	13.0	102	60.7	26.67	1116	0.104	
127	254	12.7	12.7	4697	8.66	12.7	5.66	218	56.0	35.3	25.9	17.4	137	60.7	20.00	1452	0.243	
152	305	12.7	12.7	5652	10.4	12.7	10.0	331	81.9	42.2	30.2	30.0	197	72.9	24.00	1774	0.295	

CUT FROM EXTREN® I-SHAPES

76.2	76.2	6.35	6.35	929	1.73	6.35	0.516	24.3	9.34	23.6	21.3	0.237	6.23	16.0	12.00	445	0.012
76.2	76.2	9.53	9.53	1361	2.53	9.53	0.733	32.4	13.6	23.1	22.6	0.358	9.34	16.3	8.00	632	0.039
102	102	9.53	9.53	1845	3.44	9.53	1.81	62.6	24.9	31.2	29.0	0.841	16.6	21.8	10.67	877	0.053
102	102	12.7	12.7	2419	4.49	12.7	2.31	77.2	32.3	31.0	30.0	1.12	22.1	21.6	8.00	1129	0.122
127	127	9.53	9.53	2329	4.30	9.53	3.64	103	39.7	39.4	35.3	1.64	25.7	26.4	13.33	1116	0.068
127	127	12.7	12.7	3065	5.64	12.7	4.68	129	51.8	39.1	36.3	2.19	34.4	26.7	10.00	1452	0.157
152	152	12.7	12.7	3710	6.88	12.7	8.29	194	75.5	47.2	42.7	3.77	49.5	32.0	12.00	1774	0.19

NOTE: Radius dimensions listed above are for reference only. If measurements are critical, please contact Strongwell.

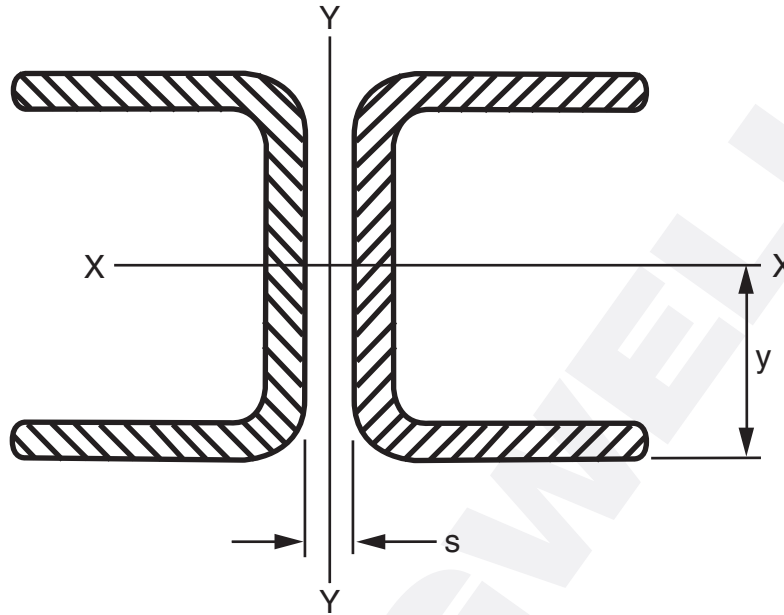

DOUBLE EXTREN® CHANNELS

PHYSICAL PROPERTIES						SECTION PROPERTIES						
SIZE				A 2 chan	NOM. Wt/ft 2 chan	AXIS X—X				RADI OF GYRATION AXIS Y—Y		
d	b _f	t _w	t _f			I	S	r	y	s, BACK TO BACK OF CHANNELS - IN.		
mm	mm	mm	mm	mm ²	kg	mm ⁴ x10 ⁶	mm ³ x10 ³	mm	mm	0	6.35	12.7
38.1	38.1	6.35	6.35	1290	2.23	0.266	13.9	14.2	19.1	17.8	20.6	23.4
76.2	25.4	4.76	4.76	1123	2.02	0.857	22.5	27.7	38.1	9.91	12.2	15.0
76.2	22.2	6.35	6.35	1297	2.29	0.961	25.2	26.4	38.1	8.89	11.7	14.2
102	34.9	4.76	4.76	1497	2.80	2.19	42.9	36.3	50.8	13.5	15.7	18.3
102	28.6	6.35	6.35	1781	3.30	2.39	47.0	37.6	50.8	10.7	13.2	16.0
127	34.9	6.35	6.35	2271	4.17	4.81	75.7	45.5	63.5	12.7	15.0	17.8
152	41.3	6.35	6.35	2748	5.00	8.51	112	54.9	76.2	15.0	17.3	20.1
152	42.9	9.53	9.53	4174	7.32	12.1	159	53.8	76.2	16.0	18.5	21.1
203	55.6	6.35	6.35	3832	6.91	21.0	207	73.9	102	20.3	22.1	24.4
203	55.6	9.53	9.53	5626	10.1	29.8	293	72.9	102	19.8	22.1	24.6
254	69.9	12.7	12.7	9355	16.4	77.0	606	90.7	127	25.4	27.7	30.2
356	88.9	19.1	19.1	18871	33.4	294	1651	125	178	32.0	34.3	36.6
457	55.6	4.76	4.76	5335	11.5	126	550	153	229	14.7	16.5	18.8

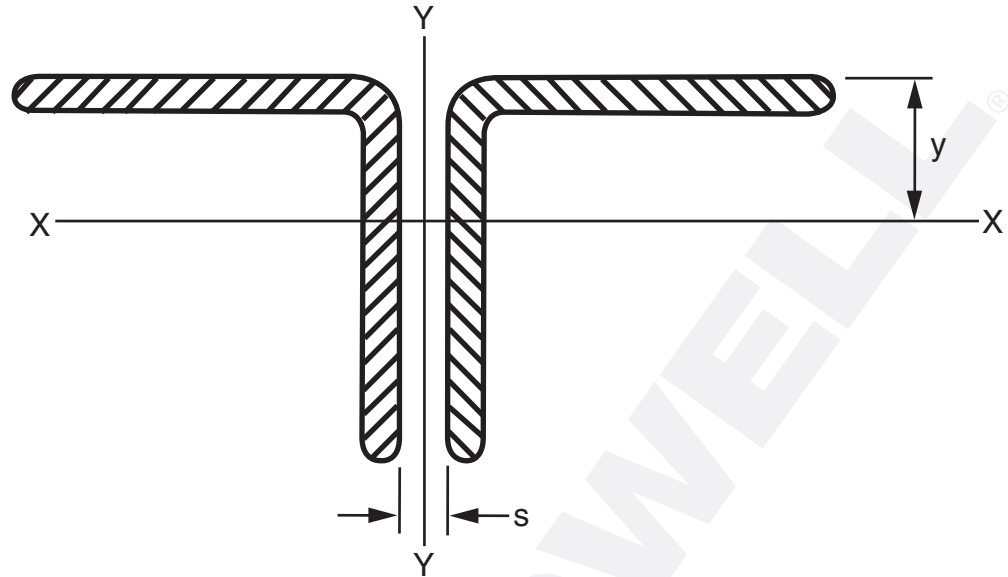

**DOUBLE ANGLES
EXTREN® EQUAL LEG ANGLES**

PHYSICAL PROPERTIES				SECTION PROPERTIES						
SIZE		A 2 angles mm ²	NOM. Wt/ft 2 angles kg	AXIS X—X				RADII OF GYRATION AXIS Y—Y		
b	t			I	S	r	y	s, BACK TO BACK OF CHANNELS - IN.		
mm	mm			mm ⁴ x10 ⁶	mm ³ x10 ³	mm	mm	0	6.35	12.7
38.1	6.35	865	1.49	0.108	4.26	11.2	11.7	16.3	18.5	21.3
50.8	6.35	1187	2.17	0.283	7.87	15.2	14.7	21.6	23.9	26.4
76.2	6.35	1832	3.36	0.982	17.7	23.1	20.8	31.8	34.0	36.3
76.2	9.53	2697	4.94	1.42	26.2	22.9	22.1	32.3	34.5	37.1
102	6.35	2477	4.58	2.45	32.8	31.2	27.2	42.2	44.2	46.5
102	9.53	3665	6.88	3.55	48.5	31.0	28.4	42.7	45.0	47.2
102	12.7	4839	8.51	4.63	64.6	31.0	30.0	43.2	45.2	47.8
152	6.35	3794	6.99	8.91	80.0	48.5	40.4	63.5	65.5	67.8
152	9.53	5600	10.2	12.4	111	47.0	40.6	63.2	65.5	67.6
152	12.7	7381	13.8	16.1	146	46.7	42.2	63.8	65.8	67.3

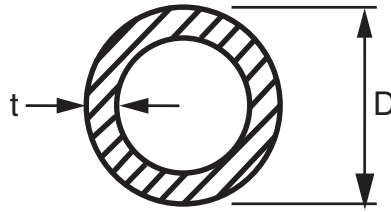

EXTREN® ROUND TUBES

PHYSICAL PROPERTIES				SECTION PROPERTIES			DESIGN PROPERTIES	
SIZE		A	NOM. Wt/ft	AXIS X—X OR Y—Y			D — t	J mm ⁴ x10 ⁶
D	t			I	S	r		
mm	mm	mm ²	kg	mm ⁴ x10 ⁶	mm ³ x10 ³	mm		mm ⁴ x10 ⁶
25.4	3.18	219	0.372	0.014	1.15	7.87	8.00	0.029
31.8	3.18	284	0.476	0.029	1.80	10.2	10.00	0.058
38.1	3.18	348	0.670	0.054	2.79	12.4	12.00	0.108
38.1	6.35	632	1.18	0.083	4.42	11.4	6.00	0.166
44.5	3.18	413	0.699	0.087	3.93	14.7	14.00	0.175
44.5	6.35	761	1.40	0.142	6.39	13.7	7.00	0.283
50.8	3.18	477	0.893	0.133	5.24	16.8	16.00	0.271
50.8	6.35	884	1.67	0.225	8.85	15.7	8.00	0.445
63.5	6.35	1142	2.13	0.470	14.9	20.3	10.00	0.941
69.9	6.35	1265	2.19	0.645	18.5	22.6	11.00	1.29
69.9	9.53	1806	3.26	0.841	24.1	21.6	7.33	1.68
76.2	6.35	1394	2.53	0.857	22.5	24.9	12.00	1.71
88.9	3.56	955	1.80	0.870	19.5	30.2	25.00	1.74
88.9	12.7	3039	5.64	2.27	51.0	27.4	7.00	4.54
102	6.35	1897	3.51	2.16	42.6	33.8	16.00	4.33
127	6.35	2406	4.58	4.39	69.2	42.7	20.00	8.78
152	3.18	1490	2.86	4.15	54.4	52.8	48.00	8.29
152	6.35	2916	5.60	7.78	102	51.8	24.00	15.6

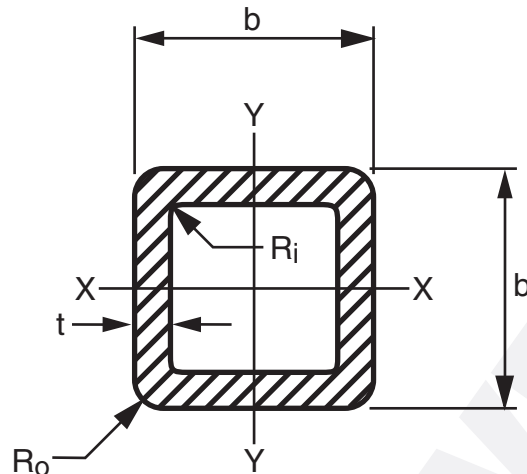

EXTREN® SQUARE TUBES

PHYSICAL PROPERTIES				SECTION PROPERTIES				DESIGN PROPERTIES			
SIZE		A	NOM. Wt/ft	RADII		I	S	r	A _w 2 Webs	b — t	J
b	t			R _o	R _i						
mm	mm	mm ²	kg	mm	mm	mm ⁴ x10 ⁶	mm ³ x10 ³	mm	mm ²		mm ⁴ x10 ⁶
25.4	3.18	277	0.476	3.962	0.79375	0.025	1.80	9.14	123	8.00	0.040
31.8	3.18	361	0.610	3.962	2.381	0.050	3.11	11.7	161	10.00	0.084
38.1	3.18	439	0.744	3.962	3.175	0.092	4.75	14.2	200	12.00	0.154
38.1	6.35	800	1.46	3.962	0.79375	0.142	7.37	13.2	323	6.00	0.239
44.5	3.18	523	0.952	3.962	0.79375	0.150	6.72	17.0	245	14.00	0.253
44.5	6.35	961	1.77	3.962	0.79375	0.241	10.8	15.7	406	7.00	0.407
50.8	3.18	600	1.10	3.962	3.175	0.229	9.01	19.6	284	16.00	0.389
50.8	6.35	1123	2.08	3.962	3.175	0.379	14.9	18.5	484	8.00	0.642
63.5	6.35	1452	2.66	3.962	0.79375	0.799	25.2	23.4	645	10.00	1.35
76.2	3.18	923	1.73	3.962	3.175	0.824	21.6	30.0	445	24.00	1.40
76.2	6.35	1768	3.27	3.962	3.175	1.46	38.2	28.7	806	12.00	2.46
76.2	9.53	2516	4.62	3.962	3.175	1.89	4.95	27.4	1090	8.00	2.82
88.9	6.35	2084	3.85	3.962	3.175	2.37	53.3	33.8	968	14.00	3.57
101.6	6.35	2413	4.58	3.962	3.175	3.67	72.3	38.9	1129	16.00	6.22
101.6	9.53	3535	6.49	3.962	3.175	4.95	97.5	37.6	1574	10.67	7.43
152.4	9.53	5265	9.66	15.875	6.35	15.99	209.9	55.1	2542	16.00	27.78

NOTE: Telescoping of square tubes cannot be guaranteed due to thickness tolerances.

NOTE: Radius dimensions listed above are for reference only. If measurements are critical, please contact Strongwell.

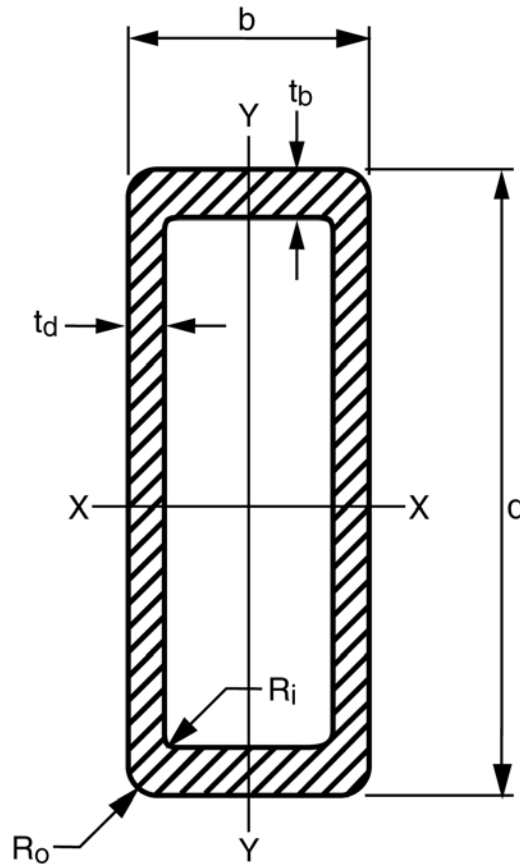

EXTREN® RECTANGULAR SHAPES

PHYSICAL PROPERTIES						SECTION PROPERTIES							DESIGN PROPERTIES					
SIZE				A	NOM. Wt/ft	RADII		AXIS X—X			AXIS Y—Y			A _w 2 Webs		b t _b	d t _d	J
d	b	t _d	t _b			R _o	R _i	I	S	r	I	S	r	x-x	y-y			
mm	mm	mm	mm	mm ²	kg	mm	mm	mm ⁴ x10 ⁶	mm ³ x10 ³	mm	mm ⁴ x10 ⁶	mm ³ x10 ³	mm	mm ²	mm ²			mm ⁴ x10 ⁶
63.5	41.3	3.18	3.18	626	1.12	3.18	6.35	0.337	10.7	23.1	0.171	8.19	18.0	361	219	13.00	20.00	0.341
102	50.8	3.18	6.35	1213	2.26	2.39	1.59	1.84	36.2	38.9	0.458	18.00	19.6	606	484	8.00	32.00	1.00
140	89.0	6.35	6.35	2671	4.81	9.53	3.18	6.87	98.3	50.5	3.37	75.9	35.6	1613	968	14.00	22.00	7.13
165	50.8	6.35	12.70	3065	5.61	1.59	1.59	10.40	126.0	58.2	1.16	45.70	19.6	1774	968	4.00	26.00	3.34
177	101.6	6.35	6.35	3387	6.10	6.35	6.35	14.20	159.8	64.8	5.85	115.20	41.6	2097	1129	16.00	27.90	12.70
229	152.0	7.95	7.95	5652	10.40	14.30	6.35	42.20	369.2	86.4	22.31	292.80	62.7	3413	2206	20.40	30.74	44.12
229	152.0	11.10	11.10	7810	14.30	14.20	3.18	54.30	475.0	83.3	28.60	375.00	60.4	4580	2890	13.70	20.60	58.30

NOTE: Radius dimensions listed above are for reference only. If measurements are critical, please contact Strongwell.

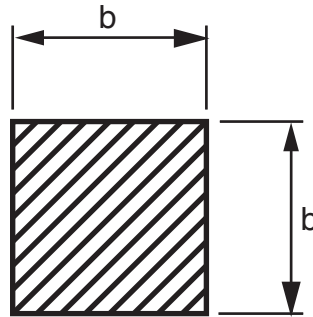

SQUARE BARS

PHYSICAL PROPERTIES			SECTION PROPERTIES			DESIGN PROPERTIES
b	A	NOM. Wt/ft	I	S	r	J
mm	mm ²	kg	mm ⁴ x10 ³	mm ³ x10 ³	mm	mm ⁴ x10 ³
12.7	155	0.327	2.08	0.344	3.66	3.75
15.9	252	0.506	5.41	0.672	4.57	9.16
19.1	361	0.729	10.8	1.15	5.49	18.7
25.4	639	1.29	345	2.74	7.34	58.7
31.8	1006	1.95	84.5	5.34	9.17	143
38.1	1445	2.84	176	9.21	11.0	297

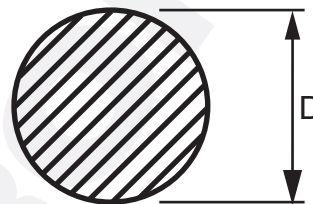

ROUND ROD

PHYSICAL PROPERTIES			SECTION PROPERTIES			DESIGN PROPERTIES
D	A	NOM. Wt/ft	I	S	r	J
mm	mm ²	kg	mm ⁴ x10 ³	mm ³ x10 ³	mm	mm ⁴ x10 ³
6.35	32.3	0.060	0.080	0.033	1.60	0.401
7.94	49.5	0.100	0.195	0.0491	1.98	0.160
9.53	71.0	0.149	0.416	0.082	2.39	0.832
12.7	129	0.253	1.25	0.197	3.18	2.50
15.9	129	0.402	2.91	0.393	3.96	6.24
19.1	200	0.580	6.66	0.672	4.78	12.9
20.6	335	0.670	8.74	0.869	5.16	17.9
22.2	387	0.789	12.1	1.08	5.56	24.1
25.4	510	1.03	20.4	1.61	6.35	40.8
28.6	606	1.26	32.9	2.29	7.14	65.3
31.8	800	1.64	49.9	3.15	7.92	99.9
38.1	1142	2.26	103	5.42	9.53	207
50.8	2026	4.00	327	12.9	12.7	654

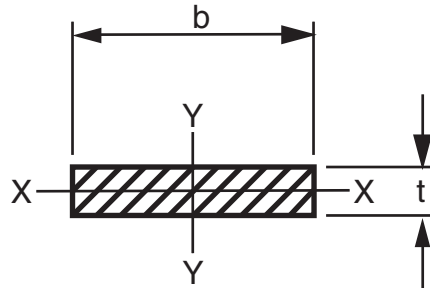

FLAT STRIP

PHYSICAL PROPERTIES				SECTION PROPERTIES					
SIZE		A	NOM. Wt/m	AXIS X—X			AXIS Y—Y		
b	t			I	S	r	I	S	r
mm	mm	mm ²	kg	mm ⁴ x10 ³	mm ³ x10 ³	mm	mm ⁴ x10 ³	mm ³ x10 ³	mm
50.8	4.76	242	0.445	0.457	0.192	1.37	52.0	2.050	14.7
50.8	6.35	323	0.593	1.080	0.341	1.83	69.4	2.730	14.7
76.2	4.76	361	0.667	0.666	0.288	1.38	176	4.600	22.0
76.2	6.35	484	0.890	1.623	0.513	1.83	234	6.145	22.0
76.2	9.53	726	1.335	5.479	1.151	2.74	351	9.218	21.9
76.2	12.70	968	1.780	13.000	2.048	3.67	468	12.290	22.0
101.6	12.70	1290	2.382	17.400	2.733	3.67	1110	21.850	29.3
152.4	6.35	962	1.775	3.243	1.022	1.83	1844	24.450	43.7
305	6.35	1935	3.750	6.504	2.048	1.83	14984	98.322	88.0

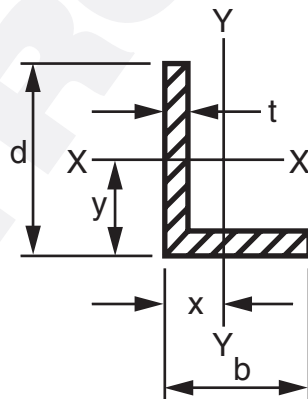

UNEQUAL LEG ANGLE

PHYSICAL PROPERTIES					SECTION PROPERTIES								
d	b	t	NOM. Wt/ft	A	AXIS X—X				AXIS Y—Y				AXIS Z—Z
					I	S	r	y	I	S	r	x	r
mm	mm	mm	kg	mm ²	mm ⁴ x10 ³	mm ³ x10 ³	mm ³	mm	mm ⁴ x10 ³	mm ³ x10 ³	mm	mm	mm
44.5	31.8	6.35	0.759	444	85.3	2.93	13.9	15.3	35.4	1.56	8.94	8.94	6.61

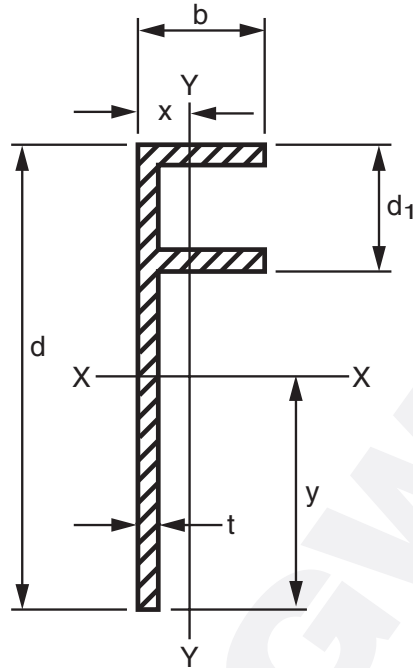

F SECTION

PHYSICAL PROPERTIES						SECTION PROPERTIES								
d	d ₁	b	t	NOM. Wt/ft	A	AXIS X—X					AXIS Y—Y			
						I	S _x	S _y	r	y	I	S	r	x
mm	mm	mm	mm	kg	mm ²	mm ⁴ x10 ³	mm ³ x10 ³	mm ³ x10 ³	mm	mm	mm ⁴ x10 ³	mm ³ x10 ³	mm	mm
140	38.1	38.1	6.35	2.35	1290	2260	42.0	26.4	41.9	85.7	142	14.2	10.2	9.12
152	50.8	38.1	6.35	2.50	1374	2810	47.9	45.9	45.7	93.0	140	16.0	9.32	8.79

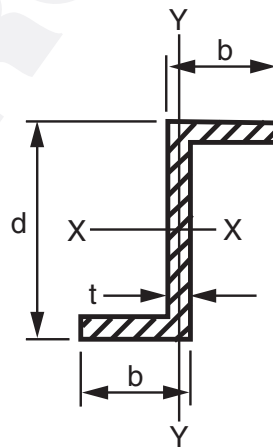

Z SECTION

PHYSICAL PROPERTIES					SECTION PROPERTIES						DESIGN PROPERTIES
b	d	t	NOM. Wt/ft	A	AXIS X—X			AXIS Y—Y			J
					I	S	r	I	S	r	
mm	mm	mm	kg	mm ⁴	mm ⁴ x10 ³	mm ³ x10 ³	mm	mm ⁴ x10 ³	mm ³ x10 ³	mm	mm ⁴ x10 ³
31.8	63.5	3.18	0.699	383	233	7.37	24.6	57.9	1.92	12.2	1.25

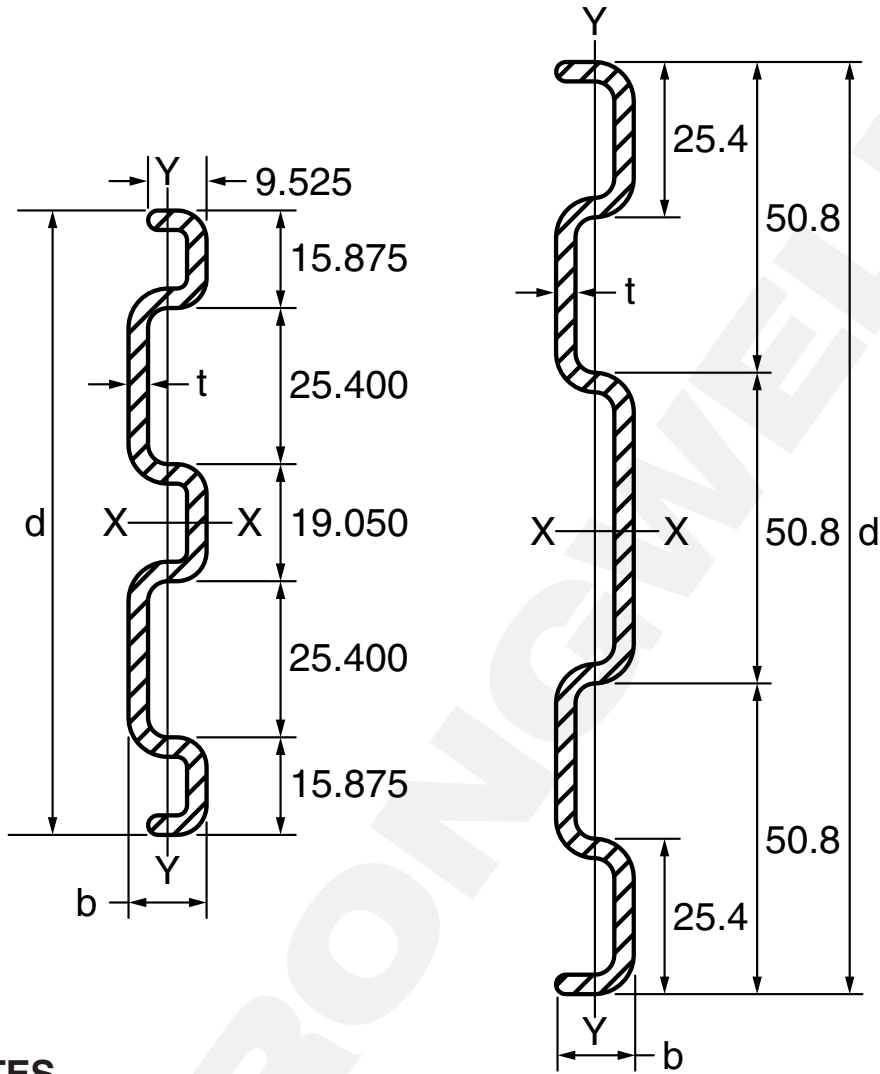

KICK PLATES

PHYSICAL PROPERTIES					SECTION PROPERTIES					
d	b	t	NOM. Wt/m	A	AXIS X—X			AXIS Y—Y		
					I	S	r	I	S	r
mm	mm	mm	kg	mm ²	mm ⁴ x10 ³	mm ³ x10 ³	mm	mm ⁴ x10 ³	mm ³ x10 ³	mm
102	12.7	3.18	0.77	430	402	7.94	30.6	7.08	1.05	4.09
152	12.7	3.18	1.09	598	1300	17075.32	46.6	10.8	1.54	4.24

SQUARE TUBE / ROUND HOLE

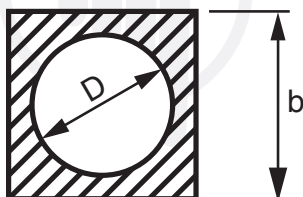

PHYSICAL PROPERTIES				SECTION PROPERTIES		
b	D	NOM. Wt/ft	A	I	S	r
mm	mm	kg	mm ²	mm ⁴ x10 ³	mm ³ x10 ³	mm
25.4	19.1	0.729	360	28.3	2.23	8.84

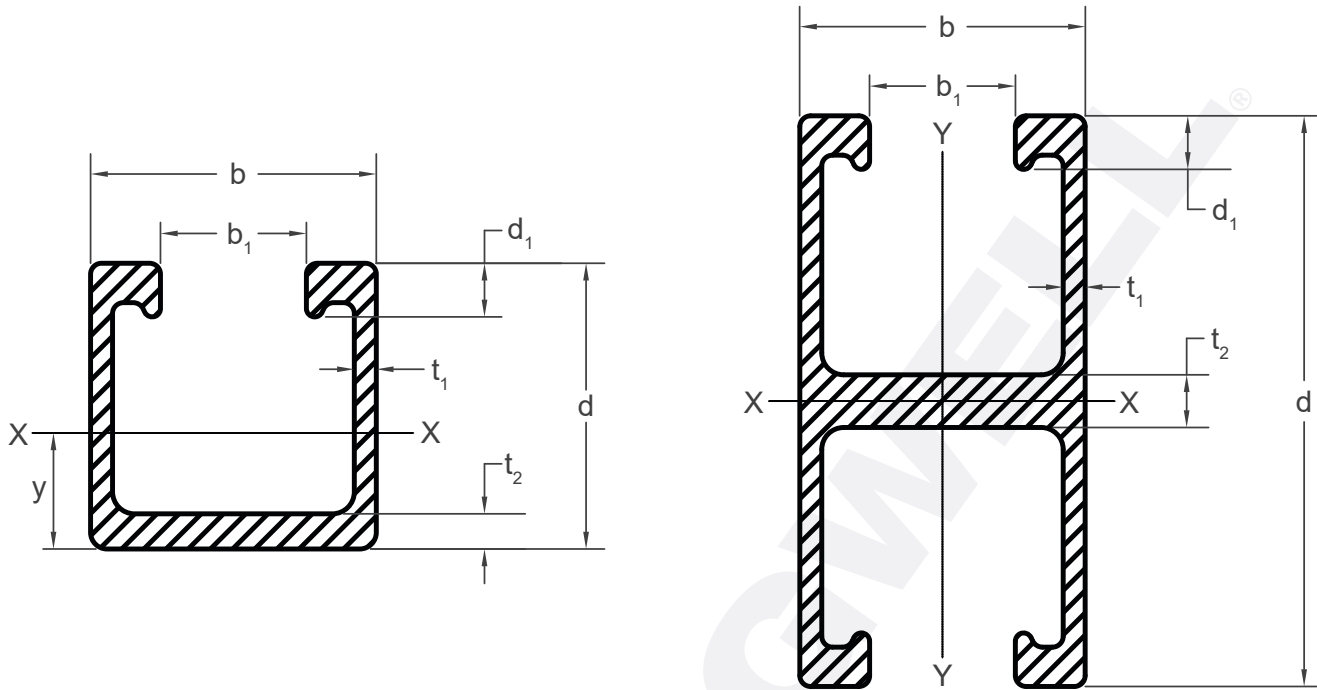

STRUTS (LEFT)

PHYSICAL PROPERTIES							SECTION PROPERTIES						DESIGN PROPERTIES
d	d ₁	b	b ₁	t ₁	t ₂	NOM. Wt/ft	AXIS X—X						J
							A	I	S _t	S _b	r	y	
mm	mm	mm	mm	mm	mm	kg	mm ²	mm ⁴ x10 ³	mm ³ x10 ³	mm ³ x10 ³	mm	mm	mm ⁴ x10 ³
41.3	7.14	41.3	22.2	3.97	3.97	0.967	439	96.6	4.23	5.28	14.8	18.3	1.66
41.3	7.75	41.3	21.1	3.18	5.08	1.016	529	116.5	4.88	6.70	14.8	17.4	3.55
26.2	7.75	41.3	21.1	3.18	3.96	0.757	394	34.1	2.29	3.01	9.3	11.3	2.33

DOUBLE STRUTS (RIGHT)

82.6	7.75	41.3	21.1	3.18	7.62	1.871	974	253.9	13.34	13.34	23.8	41.3	9.55
51.6	7.75	41.3	21.1	3.18	5.08	1.323	688	161.7	6.27	6.27	15.3	25.8	4.94

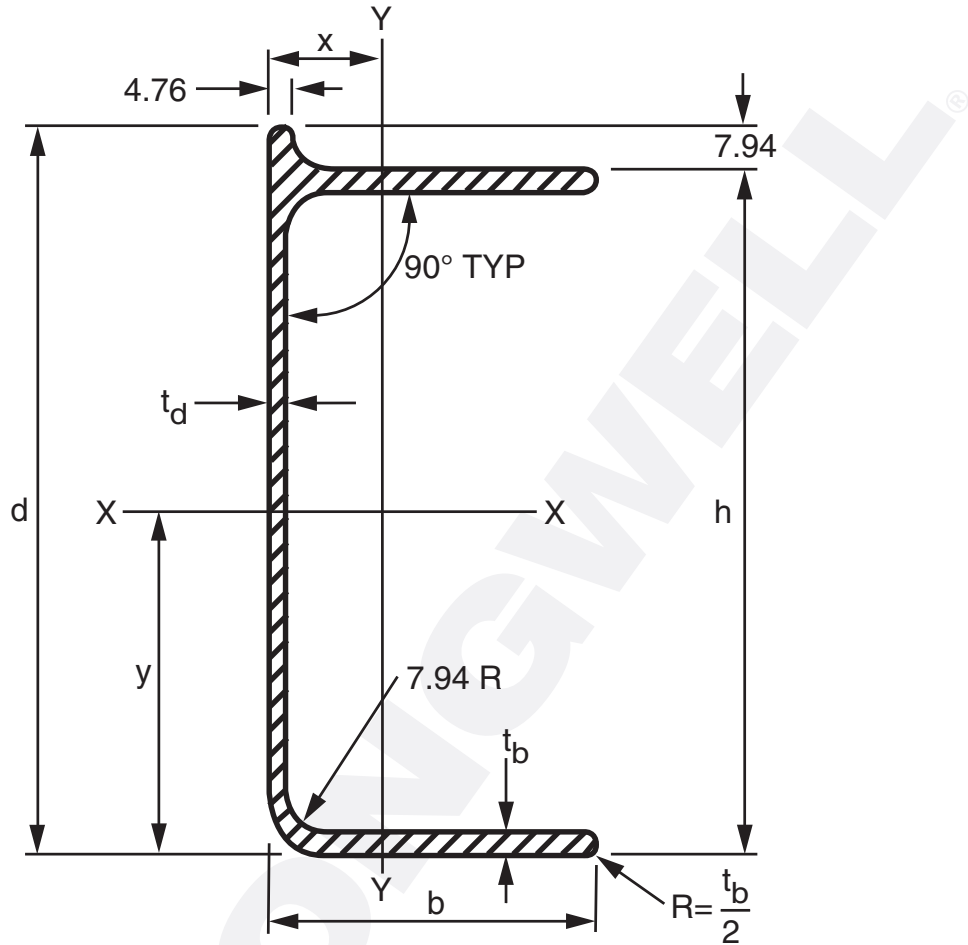

FLIGHT CHANNEL

PHYSICAL PROPERTIES							SECTION PROPERTIES									
h	d	b	t _d	t _b	NOM. Wt/ft	A	AXIS X—X					AXIS Y—Y				
							I	S _t	S _b	r	y	I	S _t	S _r	r	x
mm	mm	mm	mm	mm	kg	mm ²	mm ⁴ ×10 ³	mm ³ ×10 ³	mm ³ ×10 ³	mm	mm	mm ⁴ ×10 ³	mm ³ ×10 ³	mm ³ ×10 ³	mm	mm
133	141	63.5	3.18	4.76	1.98	1019	3192	39.3	44.1	53.6	66.5	423	22.6	10.0	20.8	19.6
181	189	63.5	3.18	4.76	2.35	1258	6489	63.6	69.6	70.6	98.8	463	24.7	11.3	23.4	16.3

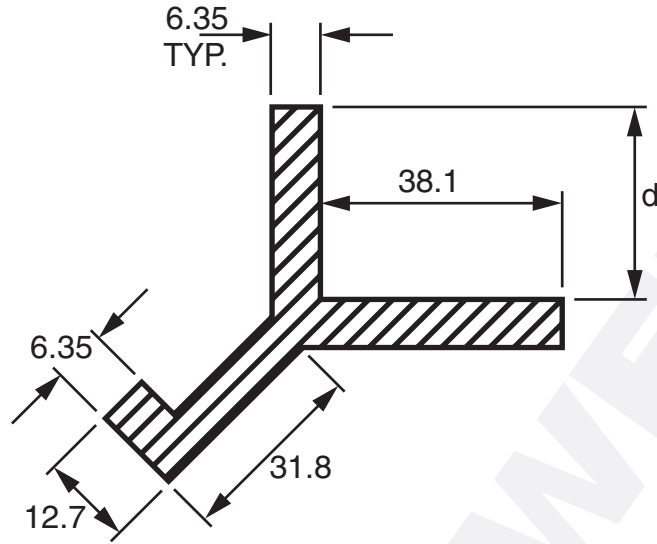

CURB ANGLES

PHYSICAL PROPERTIES			SECTION PROPERTIES									
b	NOM. Wt/ft	A	AXIS X—X					AXIS Y—Y				
			I	S _t	S _b	Y	r _x	I	S _t	S _b	X	r _y
mm	kg	mm ²	mm ⁴ x10 ³	mm ³ x10 ³	mm ³ x10 ³	mm	mm	mm ⁴ x10 ³	mm ³ x10 ³	mm ³ x10 ³	mm	mm
25.4	1.24	658	114	3.77	4.72	25.7	13.2	228	5.77	9.39	24.3	18.6
38.1	1.38	787	213	5.42	7.26	29.5	16.9	233	5.83	9.7	24	17.2
50.8	1.95	877	370	7.75	11	33.8	20.5	234	7.75	9.78	23.9	10.5

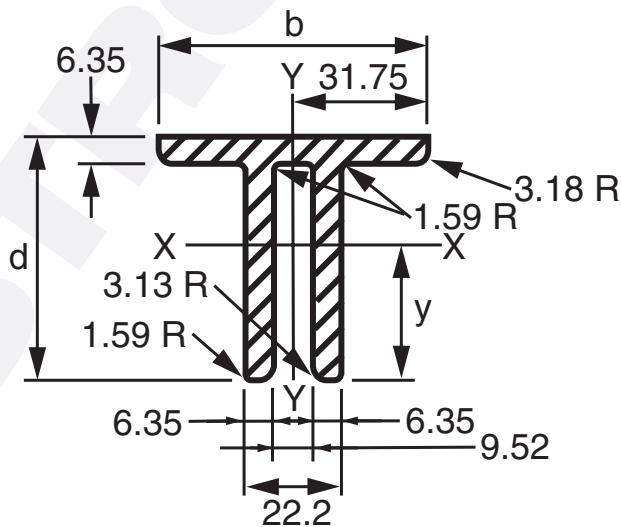

SLIDE GUIDE

PHYSICAL PROPERTIES					SECTION PROPERTIES							
b	d	t	NOM. Wt/ft	A	AXIS X—X					AXIS Y—Y		
					I	S _t	S _b	r	y	I	S	r
mm	mm	mm	kg	mm ⁴	mm ⁴ x10 ³	mm ³ x10 ³	mm ³ x10 ³	mm	mm	mm ⁴ x10 ³	mm ³ x10 ³	mm
63.5	57.2	6.35	1.68	1048	343	16.6	9.41	18.1	36.3	178	5.62	13

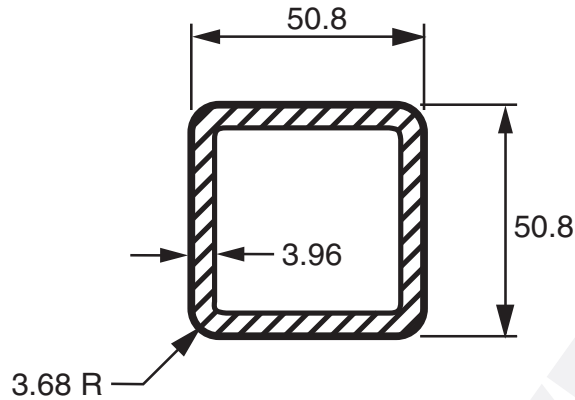

SAFRAIL™ SQUARE POST OR RAIL SECTION

PHYSICAL PROPERTIES		SECTION PROPERTIES				DESIGN PROPERTIES	
A	NOM. Wt/ft	I	S	r	A _w Z Webs	b — t	J
mm ²	kg	mm ⁴ x10 ³	mm ³ x10 ³	mm	mm ²		mm ⁴ x10 ³
743	1.41	273	10.8	19.3	399	12.9	407

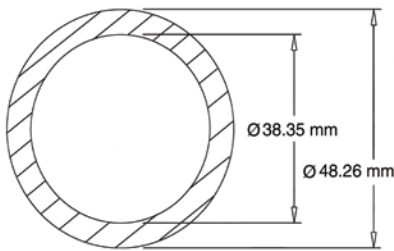

SAFRAIL™ ROUND POST OR RAIL SECTION

PHYSICAL PROPERTIES		SECTION PROPERTIES	
A	NOM. Wt/ft	I	S
mm ²	kg	mm ⁴ x10 ⁶	mm ³ x10 ³
682	1.28	0.16	6.6

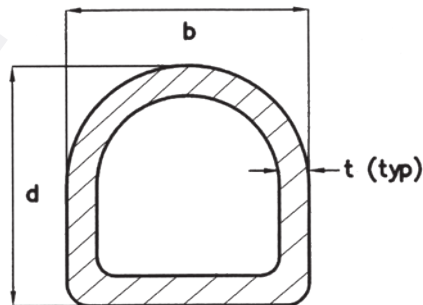

HALF ROUND RAIL SECTION

PHYSICAL PROPERTIES						SECTION PROPERTIES								
b	d	t	A	NOM. Wt/ft	\bar{y}	AXIS X—X					AXIS Y—Y			
						I	S _t	S _b	r	A _w	I	S	r	A _w
mm	mm	mm	mm ²	kg	mm	mm ⁴ x10 ⁶	mm ³ x10 ³	mm ³ x10 ³	mm	mm ²	mm ⁴ x10 ⁶	mm ³ x10 ³	mm	mm ²
50.8	50.8	6.35	973	1.83	20.3	0.32	15.5	10.3	17.8	405.8	0.34	13.4	18.5	682.8