

SECTION 6 - ELEMENTS OF SECTIONS

Table of Contents

Symbols for Elements of Sections.....	6-2
Introduction	6-3
Large EXTREN® Structural Shapes.....	6-3
Double Web Beams.....	6-3

Tables

EXTREN® W-Shapes.....	6-4	F Section	6-16
EXTREN® I-Shapes	6-5	Z-Section	6-16
EXTREN® Channels	6-6	Kick Plates.....	6-17
EXTREN® Equal Leg Angles	6-7	Square Tube / Round Hole.....	6-17
Structural Tees (Cut from EXTREN® W & I-Shapes).....	6-8	Struts & Double Struts.....	6-18
Double EXTREN® Channels.....	6-9	Flight Channel	6-19
Double Angles / EXTREN® Equal Leg Angles.....	6-10	Curb Angles.....	6-20
EXTREN® Round Tubes	6-11	Slide Guide	6-20
EXTREN® Square Tubes.....	6-12	SAFRAIL™ Square Post or Rail Section	6-21
EXTREN® Rectangular Shapes.....	6-13	SAFRAIL™ Round Post or Rail Section	6-21
Square Bars.....	6-14	Half Round Rail Section	6-21
Round Rod	6-14		
Flat Strip	6-15		
Unequal Leg Angle.....	6-15		

SECTION 6

ELEMENTS OF SECTIONS



Look for this blue line in the left margin of the Design Manual documents. This line shows you where the latest update has been made.

SYMBOLS FOR ELEMENTS OF SECTIONS

A	Cross-sectional area (in ²)
A_w	Cross-sectional area of web or webs (in ²)
D	Outside diameter of round tube (in) Diameter of round rod (in) Diameter of round hole in square tube (in)
I	Moment of Inertia (in ⁴)
J	Torsional constant (in ⁴)
R	Radius (in)
R_f	Flange toe radius (in)
R_i	Radius of inside corner (in)
R_o	Radius of outside corner (in)
S	Section modulus (in ³)
S_b	Section modulus from the bottom of an unsymmetrical section (in ³)
S_t	Section modulus from the top of an unsymmetrical section (in ³)
Wt	Weight of section (lbs)
b	Width of section (in) Outside dimension of square tube or bar (in)
b_f	Width of flange (in)
b₁	Width between flange section in strut (in) Top width of hat section (in)
d	Full depth of section (in)
d₁	Outer depth of shape in F section (in)
r	Radius of gyration (in)
s	Spacing between back to back channels or angles (in)
t	Thickness of section (in) Wall thickness of tubes (in)
t_b	Thickness of width dimension (in)
t_d	Thickness of depth dimension (in)
t_f	Thickness of flange (in)
t_w	Thickness of web (in)
x	Distance from the outside of the web to the minor (Y-Y) axis of a channel section or other similar unsymmetrical sections (in)
y	Distance from neutral X-X axis to the outer-most fibers of a cross section (in) Distance from the back of the flange to the major (X-X) axis of a tee section or other similar unsymmetrical sections (in)

ELEMENTS OF SECTIONS

INTRODUCTION

The values shown in the following tables have been computed from the nominal dimensions of the shapes.

The tables are arranged in ascending order of sizes with values tabulated for quick reference when selecting members for design requirements. Note that section properties are given for both “strong” (X-X), and “weak” (Y-Y) axis for the nonsymmetrical shapes.

Some shapes may not be stocked at all times as regular inventory items so the designer should consult the **Availability List** before selecting a specific size for an application.

LARGE EXTREN® STRUCTURAL SHAPES

18" AND 24" EXTREN® FIBERGLASS I-SHAPES

18" and 24" **EXTREN®** I-Shapes are the largest standard structural shapes pultruded. Their design properties will allow the engineer to design larger all-composite structures, spanning greater distances than were ever possible with standard pultruded fiberglass structural shapes.

As shown in the **ELEMENTS OF SECTION** tables, an **EXTREN®** 24" I-beam has a moment of inertia of 1,903 in⁴, more than four times as stiff as the **EXTREN®** 12" x 12" x 1/2" W-shape. This means that for longer spans when shear deflections are negligible, I-24 will carry the same load as a W-12 at any given span and produce about 1/4 the deflection. Or stated another way, when shear deflection is negligible, an I-24 can carry four times the load of a W-12 and produce about the same deflection.

EXTREN® 18" and 24" I-shapes, with their unique thick flange construction, assure the engineer that stress will not normally control the design when the compression flange is adequately laterally supported. Other sections in this chapter offer suggestions for effective lateral bracing systems.

The designer is also cautioned that it may be necessary to add stiffeners between the flanges at points of concentrated loads and at supports. This is referenced in Section 8 — **FLEXURAL MEMBERS (BEAMS)** of the Strongwell *Design Manual*.

DOUBLE WEB BEAMS

8" AND 36" EXTREN DWB®

Strongwell produces two sizes of double web I-beams, an 8" x 6" DWB and a 36" x 18" DWB. They are each offered in “all glass” or “hybrid” forms (hybrid refers to the combination of the dual carbon and glass reinforcements).

The carbon/glass hybrid beam has a flexural modulus of elasticity that is approximately 6.0 x 10⁶ psi, compared to that of a standard **EXTREN®** wide flange which ranges between 2.6 to 2.8 x 10⁶ psi.

Additionally, the double web shape has significantly improved the torsional stability of the beam under load. This increased stability is very significant and reduces the beams need for lateral bracing.

Section 17 — **EXTREN DWB® DESIGN GUIDE** is devoted to design information from the 8" x 6" shape and the 36" x 18" shape.

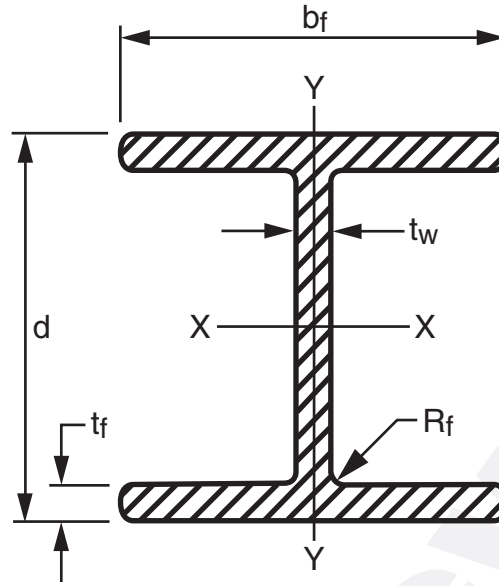

EXTREN® W-SHAPES

PHYSICAL PROPERTIES							SECTION PROPERTIES						DESIGN PROPERTIES		
SIZE				A	NOM. Wt/ft	R_f	AXIS X—X			AXIS Y—Y			$\frac{b_f}{t_f}$	A_w	J
d	b_f	t_w	t_f				I	S	r	I	S	r			
in	in	in	in	in ²	lbs	in	in ⁴	in ³	in	in ⁴	in ³	in	in ²	in ⁴	
2	2	1/8	1/8	0.72	0.60	1/16	0.50	0.50	0.83	0.17	0.17	0.48	16.00	0.22	0.004
3	3	1/4	1/4	2.13	1.79	1/8	3.17	2.11	1.22	1.13	0.75	0.73	12.00	0.63	0.044
4	4	1/4	1/4	2.89	2.43	1/8	7.94	3.97	1.66	2.67	1.34	0.97	16.00	0.88	0.060
6	6	1/4	1/4	4.39	3.69	1/8	28.28	9.43	2.54	9.00	3.00	1.44	24.00	1.38	0.091
6	6	3/8	3/8	6.48	5.44	3/16	40.17	13.40	2.50	13.52	4.50	1.45	16.00	1.97	0.303
8	8	3/8	3/8	8.73	7.33	3/16	99.18	24.80	3.38	32.03	8.01	1.92	21.33	2.72	0.409
8	8	1/2	1/2	11.51	9.67	1/4	127.06	31.76	3.33	42.74	10.69	1.93	16.00	3.50	0.958
10	10	3/8	3/8	10.98	9.22	1/4	198.82	39.70	4.26	62.54	12.50	2.39	26.67	3.47	0.514
10	10	1/2	1/2	14.55	12.22	1/4	256.20	51.20	4.22	83.42	16.65	2.40	20.00	4.50	1.208
12	12	1/2	1/2	17.51	14.71	1/4	452.70	75.50	5.07	144.10	24.00	2.88	24.00	5.50	1.458

NOTE: Radius dimensions listed above are for reference only. If measurements are critical, please contact Strongwell.

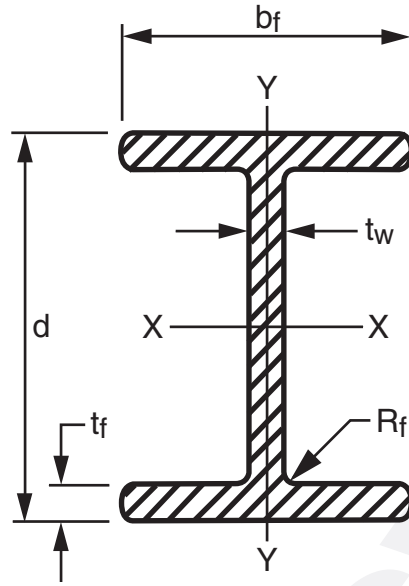

EXTREN® I-SHAPES

PHYSICAL PROPERTIES							SECTION PROPERTIES						DESIGN PROPERTIES		
SIZE				A	NOM. Wt/ft	R_f	AXIS X—X			AXIS Y—Y			$\frac{b_f}{t_f}$	A_w	J
d	b_f	t_w	t_f				I	S	r	I	S	r			
in	in	in	in	in ²	lbs	in	in ⁴	in ³	in	in ⁴	in ³	in	in ²	in ⁴	
2	1	1/8	1/8	0.47	0.39	1/16	0.28	0.28	0.77	0.02	0.04	0.21	8.00	0.22	0.002
3	1-1/2	1/4	1/4	1.38	1.16	1/8	1.75	1.17	1.13	0.14	0.19	0.32	6.00	0.63	0.029
4	2	1/4	1/4	1.89	1.59	1/8	4.40	2.20	1.54	0.34	0.34	0.43	8.00	0.88	0.039
5-1/2	2-1/2	1/4	1/4	2.48	2.08	1/8	11.12	4.04	2.12	0.62	0.50	0.50	10.00	1.25	0.055
6	3	1/4	1/4	2.88	2.42	1/8	15.92	5.32	2.36	1.13	0.76	0.63	12.00	1.38	0.060
6	3	3/8	3/8	4.23	3.55	3/16	22.30	7.43	2.31	1.71	1.14	0.64	8.00	1.97	0.198
6	4	1/4	1/4	3.43	2.76	1/4	20.40	6.80	2.44	2.68	1.34	0.88	16.00	1.38	0.070
8	4	3/8	3/8	5.73	4.81	3/16	55.45	13.85	3.12	4.03	2.02	0.84	10.67	2.72	0.268
8	4	1/2	1/2	7.51	6.31	1/4	70.62	17.65	3.08	5.41	2.71	0.85	8.00	3.50	0.625
10	5	3/8	3/8	7.23	6.07	3/16	111.67	22.33	3.93	7.85	3.14	1.04	13.33	3.47	0.338
10	5	1/2	1/2	9.51	7.99	1/4	143.48	28.70	3.90	10.51	4.22	1.06	10.00	4.50	0.788
12	6	1/2	1/2	11.51	9.67	1/4	254.10	42.30	4.70	18.11	6.05	1.26	12.00	5.50	0.958
18	4-1/2	3/8	1/2	11.09	9.32	1/2	513.30	57.00	6.80	7.67	3.41	0.83	9.00	6.38	0.674
18	8	1/2	3/4	20.36	17.11	1/2	1086.76	120.75	7.31	62.5	15.63	1.75	10.67	8.25	3.134
24	7-1/2	3/8	3/4	19.90	16.72	1/2	1903.40	158.60	9.80	52.83	14.09	1.63	10.00	8.43	2.510

NOTE: Radius dimensions listed above are for reference only. If measurements are critical, please contact Strongwell.

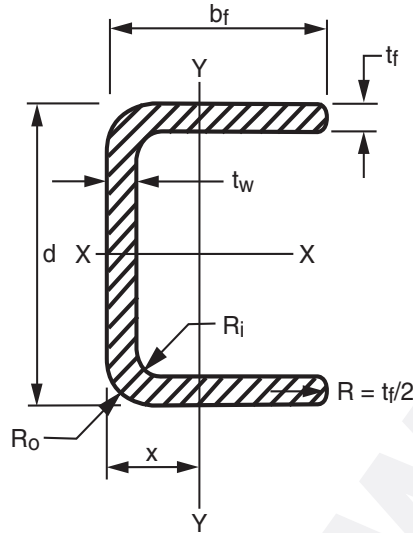

EXTREN® CHANNELS

PHYSICAL PROPERTIES								SECTION PROPERTIES								DESIGN PROPERTIES		
SIZE				A	NOM. Wt/ft	R _i	R _o	AXIS X—X			AXIS Y—Y				b _f / t _f	A _w	J	
d	b _f	t _w	t _f					I	S	r	I	S	r	x				
in	in	in	in	in ²	lbs	in	in	in ⁴	in ³	in	in ⁴	in ³	in	in	in ²	in ⁴		
1-1/2	1	3/16	3/16	0.59	0.50	1/8	5/16	0.18	0.24	0.56	0.04	0.06	0.26	0.35	5.33	0.21	0.010	
1-1/2	1-1/2	1/4	1/4	1.00	0.84	1/8	3/8	0.32	0.42	0.56	0.22	0.24	0.38	0.59	6.00	0.25	0.020	
2	9/16	1/8	1/8	0.34	0.29	1/16	3/16	0.18	0.18	0.71	0.01	0.02	0.15	0.15	4.50	0.22	0.001	
2	7/8	1/4	1/4	0.80	0.67	1/8	1/8	0.40	0.40	0.70	0.03	0.13	0.21	0.26	3.50	0.38	0.016	
2-5/8	1-1/4	1/8	3/16	0.75	0.63	1/8	3/16	0.82	0.62	1.04	0.12	0.14	0.40	0.42	6.67	0.28	0.007	
3	7/8	1/4	1/4	1.00	0.84	1/8	3/8	1.15	0.77	1.04	0.06	0.09	0.23	0.25	3.50	0.62	0.020	
3	1	3/16	3/16	0.87	0.73	1/8	5/16	1.03	0.68	1.09	0.07	0.09	0.28	0.27	5.33	0.49	0.010	
3	1-1/2	1/4	1/4	1.31	1.10	1/8	3/8	1.81	1.21	1.18	0.25	0.53	0.44	0.47	6.00	0.63	0.027	
3-1/2	1-1/2	3/16	3/16	1.11	0.93	1/8	5/16	1.91	1.09	1.31	0.19	0.18	0.41	0.42	8.00	0.59	0.013	
4	1-1/16	1/8	1/8	0.71	0.60	1/8	1/4	1.55	0.78	1.45	0.06	0.08	0.29	0.23	8.50	0.47	0.004	
4	1-1/8	1/4	1/4	1.38	1.16	1/8	3/8	2.87	1.43	1.41	0.13	0.15	0.30	0.30	4.50	0.88	0.030	
4	1-3/8	3/16	3/16	1.16	0.97	1/8	5/16	2.62	1.31	1.48	0.19	0.18	0.40	0.35	7.33	0.68	0.014	
5	1-3/8	1/4	1/4	1.76	1.48	1/8	3/8	5.78	2.31	1.79	0.25	0.24	0.37	0.34	5.50	1.12	0.040	
5-1/2	1-1/2	3/16	3/16	1.49	1.25	1/8	5/16	5.80	2.11	1.98	0.22	0.19	0.38	0.34	8.00	0.96	0.018	
5-1/2	1-1/2	1/4	1/4	2.00	1.68	1/8	5/16	7.78	2.83	1.97	0.33	0.29	0.41	0.36	6.00	1.25	0.042	
6	1-5/8	1/4	1/4	2.13	1.79	1/8	3/8	10.22	3.41	2.16	0.43	0.35	0.44	0.38	6.50	1.38	0.050	
6	1-11/16	3/8	3/8	3.23	2.71	3/16	9/16	14.55	4.85	2.12	0.54	0.44	0.41	0.44	4.50	1.97	0.150	
8	2-3/16	1/4	1/4	2.97	2.49	1/8	3/8	25.22	6.31	2.91	1.10	0.65	0.61	0.49	8.75	1.88	0.060	
8	2-3/16	3/8	3/8	4.36	3.66	3/16	9/16	35.75	8.94	2.87	1.42	0.86	0.57	0.53	5.83	2.72	0.200	
10	2-3/4	1/2	1/2	7.25	6.09	3/8	3/4	92.46	18.49	3.57	3.99	1.93	0.74	0.68	5.50	4.50	0.600	
12	3	1/2	1/2	8.17	6.86	3/8	7/8	142.8	23.8	4.18	5.07	2.20	0.79	0.70	6.00	5.50	0.750	
14	3-1/2	3/4	3/4	14.62	12.28	3/8	1-1/8	352.74	50.39	4.91	12.16	4.62	0.91	0.87	4.67	9.38	2.742	
18	2-3/16	3/16	3/8	4.14	3.48	1/16	1/4	151.02	16.78	6.04	1.00	0.55	0.53	0.29	11.67	3.31	0.049	
24	3	1/4	1/4	7.60	6.38	3/8	1/8	484.33	40.36	7.98	3.56	1.34	0.68	0.35	11.54	6.10	0.173	

NOTE: Radius dimensions listed above are for reference only. If measurements are critical, please contact Strongwell.

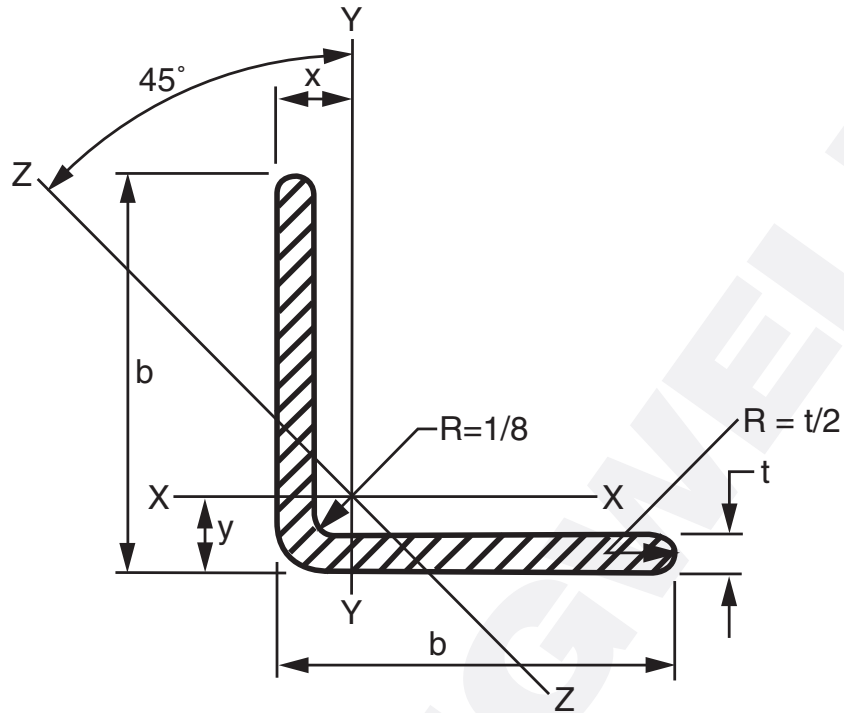

EXTREN® EQUAL LEG ANGLES

PHYSICAL PROPERTIES				SECTION PROPERTIES						DESIGN PROPERTIES	
SIZE		A	NOM. Wt/ft	AXIS X—X OR Y—Y				AXIS Z—Z		b — t	J
b	t			I	S	r	x or y	I	r		
in	in	in ²	lbs	in ⁴	in ³	in	in	in ⁴	in	in ⁴	
1	1/8	0.22	0.18	0.02	0.03	0.30	0.29	0.01	0.19	8.00	0.001
1-1/4	1/8	0.29	0.24	0.04	0.05	0.37	0.35	0.02	0.24	10.00	0.002
1-1/4	3/16	0.42	0.35	0.06	0.07	0.37	0.37	0.03	0.24	6.67	0.005
1-1/2	1/8	0.35	0.29	0.07	0.07	0.45	0.41	0.03	0.29	12.00	0.002
1-1/2	3/16	0.51	0.43	0.11	0.10	0.45	0.44	0.04	0.29	8.00	0.006
1-1/2	1/4	0.67	0.56	0.13	0.13	0.44	0.46	0.06	0.29	6.00	0.007
2	1/8	0.48	0.40	0.19	0.13	0.63	0.55	0.08	0.46	16.00	0.002
2	3/16	0.70	0.59	0.27	0.19	0.61	0.56	0.11	0.39	10.67	0.008
2	1/4	0.92	0.77	0.34	0.24	0.60	0.58	0.14	0.39	8.00	0.020
3	1/4	1.42	1.19	1.18	0.54	0.91	0.82	0.49	0.58	12.00	0.030
3	3/8	2.09	1.76	1.70	0.80	0.90	0.87	0.70	0.58	8.00	0.090
4	1/4	1.92	1.61	2.94	1.00	1.23	1.07	1.21	0.79	16.00	0.040
4	3/8	2.84	2.39	4.26	1.48	1.22	1.12	1.75	0.78	10.67	0.134
4	1/2	3.75	3.15	5.56	1.97	1.22	1.18	2.29	0.78	8.00	0.312
5	1/2	4.71	3.96	11.34	3.35	1.55	1.61	4.87	1.02	10.00	0.390
6	1/4	2.94	2.47	10.70	2.43	1.91	1.59	4.36	1.22	24.00	0.061
6	3/8	4.34	3.65	14.85	3.38	1.85	1.60	6.07	1.18	16.00	0.204
6	1/2	5.72	4.80	19.38	4.46	1.84	1.66	7.92	1.17	12.00	0.480

NOTE: Radius dimensions listed above are for reference only. If measurements are critical, please contact Strongwell.

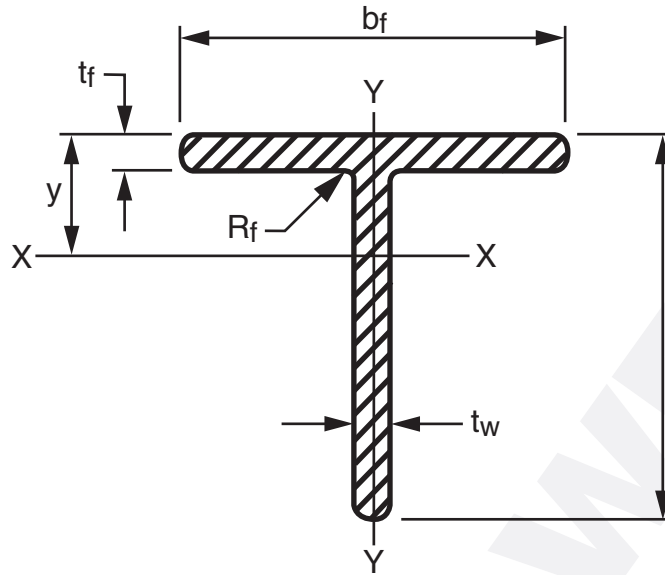

STRUCTURAL TEES

CUT FROM **EXTREN®** W-SHAPES

PHYSICAL PROPERTIES							SECTION PROPERTIES								DESIGN PROPERTIES		
SIZE				A	NOM. Wt/ft	R _f	I	AXIS X—X OR Y—Y				AXIS Z—Z			b _f — t _f	A _w	J
d	b _f	t _w	t _f					S _t	S _b	r	y	I	S	r			
in	in	in	in	in ²	lbs	in	in ⁴	in ³	in ³	in	in	in ⁴	in ³	in	in ²	in ⁴	
1-1/2	3	1/4	1/4	1.06	0.89	1/4	0.17	0.48	0.15	0.40	0.35	0.56	0.37	0.73	12.00	0.31	0.021
2	4	1/4	1/4	1.44	1.21	1/4	0.42	0.98	0.27	0.54	0.43	1.34	0.67	0.96	16.00	0.44	0.029
3	6	1/4	1/4	2.19	1.84	1/4	1.50	7.50	0.62	0.83	0.60	4.50	1.50	1.43	24.00	0.69	0.044
3	6	3/8	3/8	3.24	2.72	3/8	2.13	3.33	0.90	0.81	0.64	6.76	2.25	1.44	16.00	0.98	0.145
4	8	3/8	3/8	4.36	3.66	3/8	5.27	6.50	1.65	1.10	0.81	16.01	4.00	1.92	21.33	1.36	0.198
4	8	1/2	1/2	5.76	4.84	1/2	6.74	7.84	2.14	1.08	0.86	21.37	5.34	1.93	16.00	1.75	0.459
5	10	3/8	3/8	5.48	4.60	3/8	10.55	10.76	2.62	1.39	0.98	31.27	6.25	2.39	26.67	1.73	0.251
5	10	1/2	1/2	7.28	6.12	1/2	13.60	13.33	3.42	1.39	1.02	41.71	8.34	2.39	20.00	2.25	0.584
6	12	1/2	1/2	8.76	7.36	1/2	24.03	20.19	5.00	1.66	1.19	72.05	12.01	2.87	24.00	2.75	0.709

CUT FROM **EXTREN®** I-SHAPES

3	3	1/4	1/4	1.44	1.21	1/4	1.24	1.48	0.57	0.93	0.84	0.57	0.38	0.63	12.00	0.69	0.029
3	3	3/8	3/8	2.11	1.77	3/8	1.76	1.98	0.83	0.91	0.89	0.86	0.57	0.64	8.00	0.98	0.093
4	4	3/8	3/8	2.86	2.40	3/8	4.36	3.82	1.52	1.23	1.14	2.02	1.01	0.86	10.67	1.36	0.128
4	4	1/2	1/2	3.75	3.15	1/2	5.56	4.71	1.97	1.22	1.18	2.70	1.35	0.85	8.00	1.75	0.293
5	5	3/8	3/8	3.61	3.03	3/8	8.74	6.29	2.42	1.55	1.39	3.93	1.57	1.04	13.33	1.73	0.163
5	5	1/2	1/2	4.75	3.99	1/2	11.25	7.87	3.16	1.54	1.43	5.26	2.10	1.05	10.00	2.25	0.376
6	6	1/2	1/2	5.75	4.83	1/2	19.91	11.85	4.61	1.86	1.68	9.06	3.02	1.26	12.00	2.75	0.456

NOTE: Radius dimensions listed above are for reference only. If measurements are critical, please contact Strongwell.

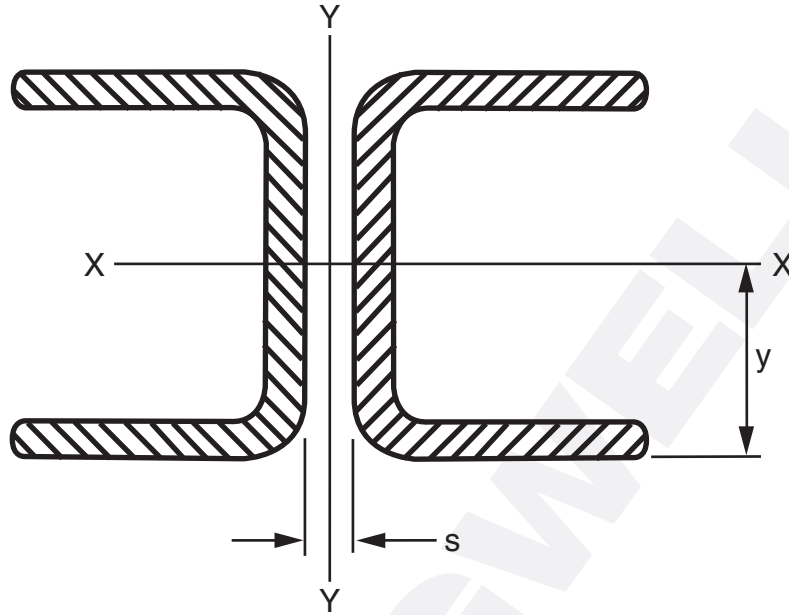

DOUBLE EXTREN® CHANNELS

PHYSICAL PROPERTIES						SECTION PROPERTIES						
SIZE				A 2 chan	NOM. Wt/ft 2 chan	AXIS X—X				RADI OF GYRATION AXIS Y—Y		
d	b _f	t _w	t _f			I	S	r	y	s, BACK TO BACK OF CHANNELS - IN.		
in	in	in	in	in ²	lbs	in ⁴	in ³	in	in	0	1/4	1/2
1-1/2	1-1/2	1/4	1/4	2.00	1.68	0.64	0.85	0.56	0.75	0.70	0.81	0.92
3	1	3/16	3/16	1.74	1.46	2.06	1.37	1.09	1.50	0.39	0.48	0.59
3	7/8	1/4	1/4	2.01	1.69	2.31	1.54	1.04	1.50	0.35	0.46	0.56
4	1-3/8	3/16	3/16	2.32	1.95	5.25	2.62	1.43	2.00	0.53	0.62	0.72
4	1-1/8	1/4	1/4	2.76	2.32	5.74	2.87	1.48	2.00	0.42	0.52	0.63
5	1-3/8	1/4	1/4	3.52	2.96	11.56	4.62	1.79	2.50	0.50	0.59	0.70
6	1-5/8	1/4	1/4	4.26	3.58	20.44	6.82	2.16	3.00	0.59	0.68	0.79
6	1-11/16	3/8	3/8	6.47	5.43	29.10	9.70	2.12	3.00	0.63	0.73	0.83
8	2-3/16	1/4	1/4	5.94	4.99	50.44	12.62	2.91	4.00	0.80	0.87	0.96
8	2-3/16	3/8	3/8	8.72	7.32	71.50	17.88	2.87	4.00	0.78	0.87	0.97
10	2-3/4	1/2	1/2	14.50	12.18	184.92	36.99	3.57	5.00	1.00	1.09	1.19
14	3-1/2	3/4	3/4	29.25	24.57	705.48	100.78	4.91	7.00	1.26	1.35	1.44
18	2-3/16	3/16	3/16	8.27	6.95	302.03	33.56	6.04	9.00	0.58	0.65	0.74

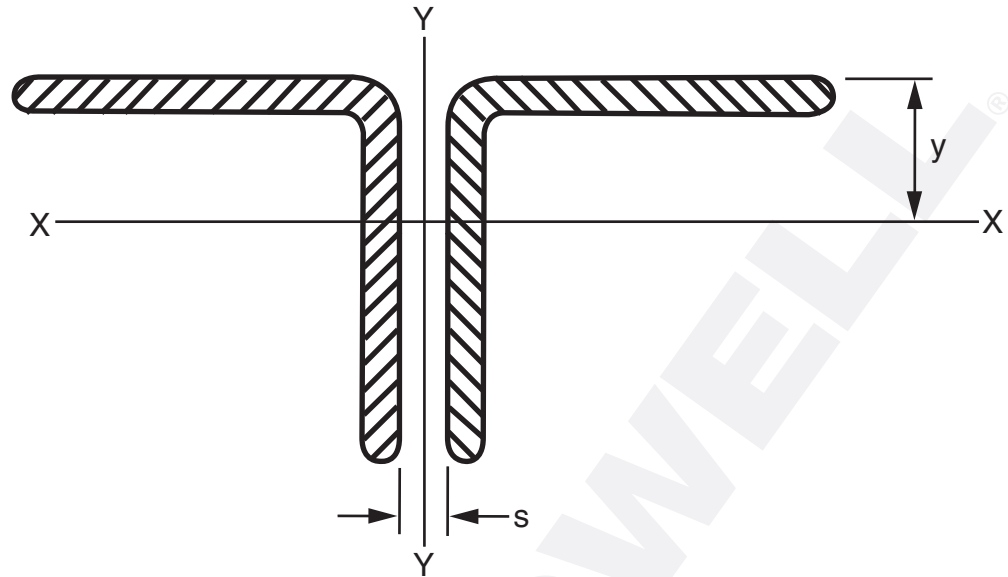

**DOUBLE ANGLES
EXTREN® EQUAL LEG ANGLES**

PHYSICAL PROPERTIES				SECTION PROPERTIES						
SIZE		A 2 angles in ²	NOM. Wt/ft 2 angles lbs	AXIS X—X				RADII OF GYRATION AXIS Y—Y		
b	t			I	S	r	y	s, BACK TO BACK OF CHANNELS - IN.		
in	in			in ⁴	in ³	in	in	0	1/4	1/2
1-1/2	1/4	1.34	1.13	0.26	0.26	0.44	0.46	0.64	0.73	0.84
2	1/4	1.84	1.55	0.68	0.48	0.60	0.58	0.85	0.94	1.04
3	1/4	2.84	2.39	2.36	1.08	0.91	0.82	1.25	1.34	1.43
3	3/8	4.18	3.51	3.40	1.60	0.90	0.87	1.27	1.36	1.46
4	1/4	3.84	3.23	5.88	2.00	1.23	1.07	1.66	1.74	1.83
4	3/8	5.68	4.77	8.52	2.96	1.22	1.12	1.68	1.77	1.86
4	1/2	7.50	6.30	11.12	3.94	1.22	1.18	1.70	1.78	1.88
6	1/4	5.88	4.94	21.40	4.88	1.91	1.59	2.50	2.58	2.67
6	3/8	8.68	7.29	29.70	6.76	1.85	1.60	2.49	2.58	2.66
6	1/2	11.44	9.61	38.76	8.92	1.84	1.66	2.51	2.59	2.65

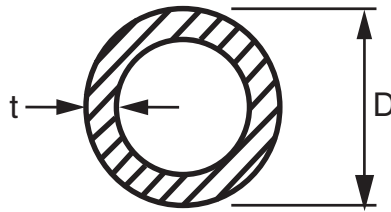

EXTREN® ROUND TUBES

PHYSICAL PROPERTIES				SECTION PROPERTIES			DESIGN PROPERTIES	
SIZE		A	NOM. Wt/ft	AXIS X—X OR Y—Y			D — t	J
D	t			I	S	r		
in	in	in ²	lbs	in ⁴	in ³	in	in ⁴	
1	1/8	0.34	0.29	0.034	0.07	0.31	8.00	0.07
1-1/4	1/8	0.44	0.37	0.07	0.11	0.40	10.00	0.14
1-1/2	1/8	0.54	0.45	0.13	0.17	0.49	12.00	0.26
1-1/2	1/4	0.98	0.82	0.20	0.27	0.45	6.00	0.40
1-3/4	1/8	0.64	0.54	0.21	0.24	0.58	14.00	0.42
1-3/4	1/4	1.18	0.99	0.34	0.39	0.54	7.00	0.68
2	1/8	0.74	0.62	0.32	0.32	0.66	16.00	0.65
2	1/4	1.37	1.15	0.54	0.54	0.62	8.00	1.07
2-1/2	1/4	1.77	1.49	1.13	0.91	0.80	10.00	2.26
2-3/4	1/4	1.96	1.65	1.55	1.13	0.89	11.00	3.10
2-3/4	3/8	2.80	2.35	2.02	1.47	0.85	7.33	4.04
3	1/4	2.16	1.81	2.06	1.37	0.98	12.00	4.12
3-1/2	.140	1.48	1.24	2.09	1.19	1.19	25.00	4.18
3-1/2	1/2	4.71	3.96	5.45	3.11	1.08	7.00	10.90
4	1/4	2.94	2.47	5.20	2.60	1.33	16.00	10.40
5	1/4	3.73	3.13	10.55	4.22	1.68	20.00	21.10
6	1/8	2.31	1.94	9.96	3.32	2.08	48.00	19.92
6	1/4	4.52	3.80	18.70	6.23	2.04	24.00	37.40

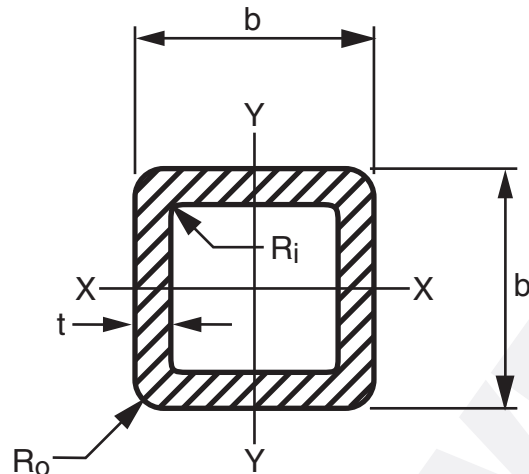

EXTREN® SQUARE TUBES

PHYSICAL PROPERTIES						SECTION PROPERTIES				DESIGN PROPERTIES	
SIZE		A	NOM. Wt/ft	RADII		I	S	r	A _w 2 Webs	b — t	J
b	t			R _o	R _i						
in	in	in ²	lbs	in	in						
1	1/8	0.43	0.36	5/32	1/32	0.06	0.11	0.36	0.19	8.00	0.060
1-1/4	1/8	0.56	0.47	5/32	3/32	0.12	0.19	0.46	0.25	10.00	0.178
1-1/2	1/8	0.68	0.57	5/32	1/8	0.22	0.29	0.56	0.31	12.00	0.325
1-1/2	1/4	1.24	1.04	5/32	1/32	0.34	0.45	0.52	0.50	6.00	0.488
1-3/4	1/8	0.81	0.68	5/32	1/32	0.36	0.41	0.67	0.38	14.00	0.536
1-3/4	1/4	1.49	1.25	5/32	1/32	0.58	0.66	0.62	0.63	7.00	0.844
2	1/8	0.93	0.78	5/32	1/8	0.55	0.55	0.77	0.44	16.00	0.824
2	1/4	1.74	1.46	5/32	1/8	0.91	0.91	0.73	0.75	8.00	1.339
2-1/2	1/4	2.25	1.89	5/32	1/32	1.92	1.54	0.92	1.00	10.00	2.848
3	1/8	1.43	1.20	5/32	1/8	1.98	1.32	1.18	0.69	24.00	2.970
3	1/4	2.74	2.30	5/32	1/8	3.50	2.33	1.13	1.25	12.00	5.199
3	3/8	3.90	3.28	5/32	1/8	4.53	3.02	1.08	1.69	8.00	6.780
3-1/2	1/4	3.25	2.73	5/32	1/8	5.86	3.35	1.34	1.50	14.00	8.582
4	1/4	3.74	3.14	5/32	1/8	8.82	4.41	1.53	1.75	16.00	13.183
4	3/8	5.48	4.60	5/32	1/8	11.90	5.95	1.48	2.44	10.67	17.860
6	3/8	8.16	6.85	5/8	1/4	42.41	14.14	2.28	3.94	16.00	66.740

NOTE: Telescoping of square tubes cannot be guaranteed due to thickness tolerances.
NOTE: Radius dimensions listed above are for reference only. If measurements are critical, please contact Strongwell.

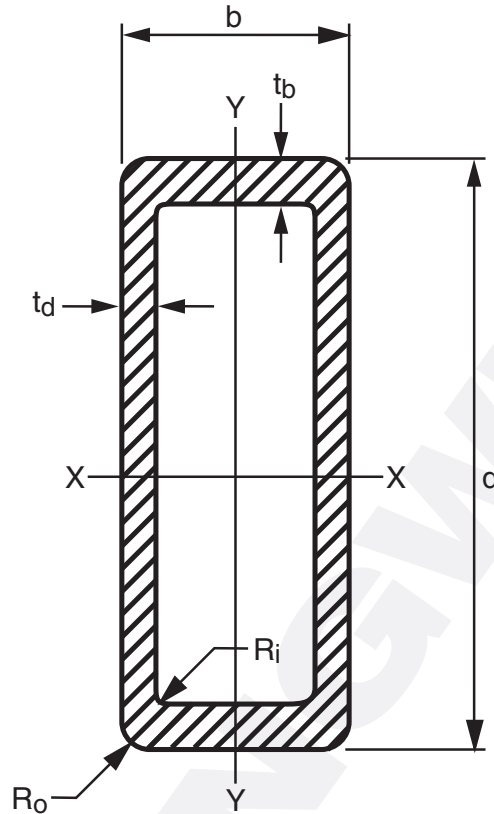

EXTREN® RECTANGULAR SHAPES

PHYSICAL PROPERTIES						SECTION PROPERTIES							DESIGN PROPERTIES					
SIZE				A	NOM. Wt/ft	RADII		AXIS X—X			AXIS Y—Y			A _w 2 Webs		b / t _b	d / t _d	J
d	b	t _d	t _b			R _o	R _i	I	S	r	I	S	r	x-x	y-y			
in	in	in	in	in ²	lbs	in	in	in ⁴	in ³	in	in ⁴	in ³	in	in ²	in ²			in ⁴
2-1/2	1-5/8	1/8	1/8	0.97	0.81	1/8	1/4	0.81	0.65	0.91	0.41	0.50	0.71	0.56	0.34	13.00	20.00	0.82
4	2	1/8	1/4	1.88	1.58	.094	1/16	4.41	2.21	1.53	1.10	1.10	0.77	0.94	0.75	8.00	32.00	2.64
5-1/2	3-1/2	1/4	1/4	4.14	3.48	3/8	1/8	16.50	6.00	1.99	8.10	4.63	1.40	2.50	1.50	14.00	22.00	17.12
6-1/2	2	1/4	1/2	4.75	3.99	1/16	1/16	24.97	7.68	2.29	2.79	2.79	0.77	2.75	1.50	4.00	26.00	8.02
7	4	1/4	1/4	5.25	4.41	1/4	1/4	34.14	9.75	2.55	14.06	7.03	1.64	3.25	1.75	16.00	28.00	30.50
9	6	5/16	5/16	8.76	7.36	9/16	1/4	101.38	22.53	3.40	53.61	17.87	2.47	5.29	3.42	19.20	28.80	106.00
9	6	7/16	7/16	12.10	10.16	9/16	1/8	130.40	29.00	3.28	68.70	22.90	2.38	7.10	4.48	13.70	20.60	140.00

NOTE: Radius dimensions listed above are for reference only. If measurements are critical, please contact Strongwell.

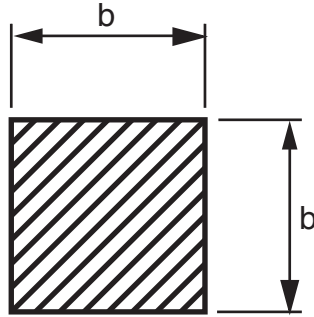

SQUARE BARS

PHYSICAL PROPERTIES			SECTION PROPERTIES			DESIGN PROPERTIES
b	A	NOM. Wt/ft	I	S	r	J
in	in ²	lbs	in ⁴	in ³	in	in ⁴
1/2	0.24	0.22	0.005	0.021	0.144	0.009
5/8	0.39	0.34	0.013	0.041	0.180	0.022
3/4	0.56	0.49	0.026	0.070	0.216	0.045
1	0.99	0.87	0.083	0.167	0.289	0.141
1-1/4	1.56	1.31	0.203	0.326	0.361	0.344
1-1/2	2.24	1.91	0.422	0.562	0.433	0.714

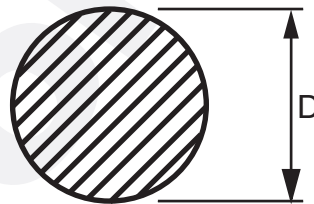

ROUND ROD

PHYSICAL PROPERTIES			SECTION PROPERTIES			DESIGN PROPERTIES
D	A	NOM. Wt/ft	I	S	r	J
in	in ²	lbs	in ⁴	in ³	in	in ⁴
1/4	0.05	0.04	<0.001	0.002	0.063	<0.001
5/16	0.08	0.07	<0.001	0.003	0.078	<0.001
3/8	0.11	0.10	0.001	0.005	0.094	0.002
1/2	0.20	0.17	0.003	0.012	0.125	0.006
5/8	0.31	0.27	0.007	0.024	0.156	0.015
3/4	0.44	0.39	0.016	0.041	0.188	0.031
13/16	0.52	0.45	0.021	0.053	0.203	0.043
7/8	0.60	0.53	0.029	0.066	0.219	0.058
1	0.79	0.69	0.049	0.098	0.250	0.098
1-1/8	0.94	0.85	0.079	0.140	0.281	0.157
1-1/4	1.24	1.10	0.120	0.192	0.312	0.240
1-1/2	1.77	1.52	0.248	0.331	0.375	0.497
2	3.14	2.69	0.785	0.785	0.500	1.571

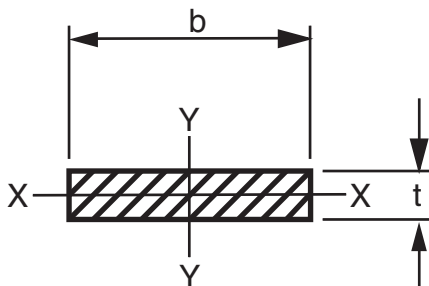

FLAT STRIP

PHYSICAL PROPERTIES				SECTION PROPERTIES					
SIZE		A	NOM. Wt/ft	AXIS X—X			AXIS Y—Y		
b	t			I	S	r	I	S	r
in	in	in ²	lbs	in ⁴	in ³	in	in ⁴	in ³	in
2	0.188	0.38	0.30	0.0011	0.0117	0.0542	0.1250	0.1250	0.577
2	0.250	0.50	0.39	0.0026	0.0208	0.0721	0.1667	0.1667	0.578
3	0.188	0.56	0.45	0.0016	0.0176	0.0542	0.4220	0.2810	0.866
3	0.250	0.75	0.59	0.0039	0.0313	0.0720	0.5625	0.3750	0.866
3	0.375	1.13	0.89	0.0132	0.0703	0.1080	0.8438	0.5625	0.864
3	0.500	1.50	1.17	0.0312	0.1250	0.1442	1.1250	0.7500	0.866
4	0.500	2.00	1.56	0.0417	0.1667	0.1440	2.6670	1.3330	1.155
6	0.250	1.50	1.17	0.0078	0.0625	0.0720	4.5000	1.5000	1.732
12	0.250	3.00	2.52	0.0160	0.1250	0.0720	36.0000	6.0000	3.464

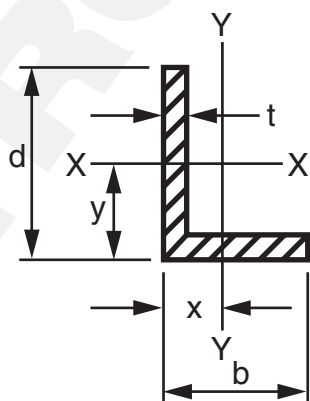

UNEQUAL LEG ANGLE

PHYSICAL PROPERTIES					SECTION PROPERTIES								
d	b	t	NOM. Wt/ft	A	AXIS X—X				AXIS Y—Y				AXIS Z—Z
					I	S	r	y	I	S	r	x	r
in	in	in	lbs	in ²	in ⁴	in ³	in	in	in ⁴	in ³	in	in	in
1-3/4	1-1/4	1/4	0.51	.688	.205	.179	.546	.602	.085	.095	.352	.352	.268

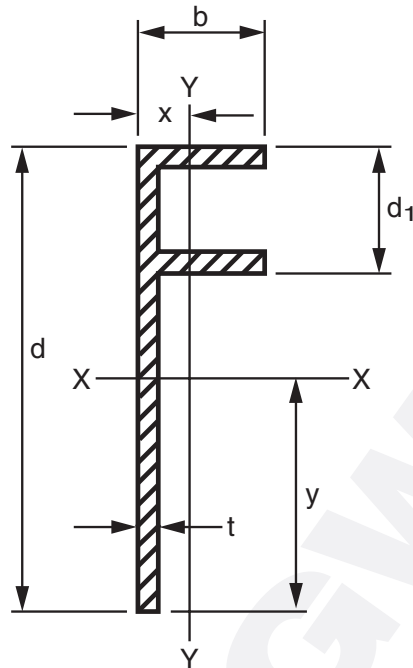

F SECTION

PHYSICAL PROPERTIES						SECTION PROPERTIES									
d	d ₁	b	t	NOM. Wt/ft	A	AXIS X—X					AXIS Y—Y				
						I	S _t	S _b	r	y	I	S	r	x	
in	in	in	in	lbs	in ²	in ⁴	in ³	in ³	in	in	in ⁴	in ³	in	in	
5-1/2	1-1/2	1-1/2	1/4	1.58	2.00	5.43	2.56	1.61	1.65	3.375	0.342	0.866	0.401	0.359	
6	2	1-1/2	1/4	1.68	2.13	6.75	2.92	2.80	1.80	3.662	0.337	0.974	0.367	0.346	

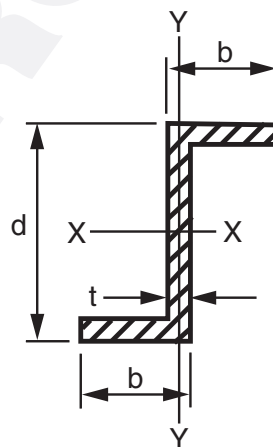

Z SECTION

PHYSICAL PROPERTIES					SECTION PROPERTIES						DESIGN PROPERTIES
b	d	t	NOM. Wt/ft	A	AXIS X—X			AXIS Y—Y			J
					I	S	r	I	S	r	
in	in	in	lbs	in ²	in ⁴	in ³	in	in ⁴	in ³	in	in ⁴
1-1/4	2-1/2	1/8	0.47	0.594	0.559	0.45	0.97	0.139	0.117	0.48	0.003

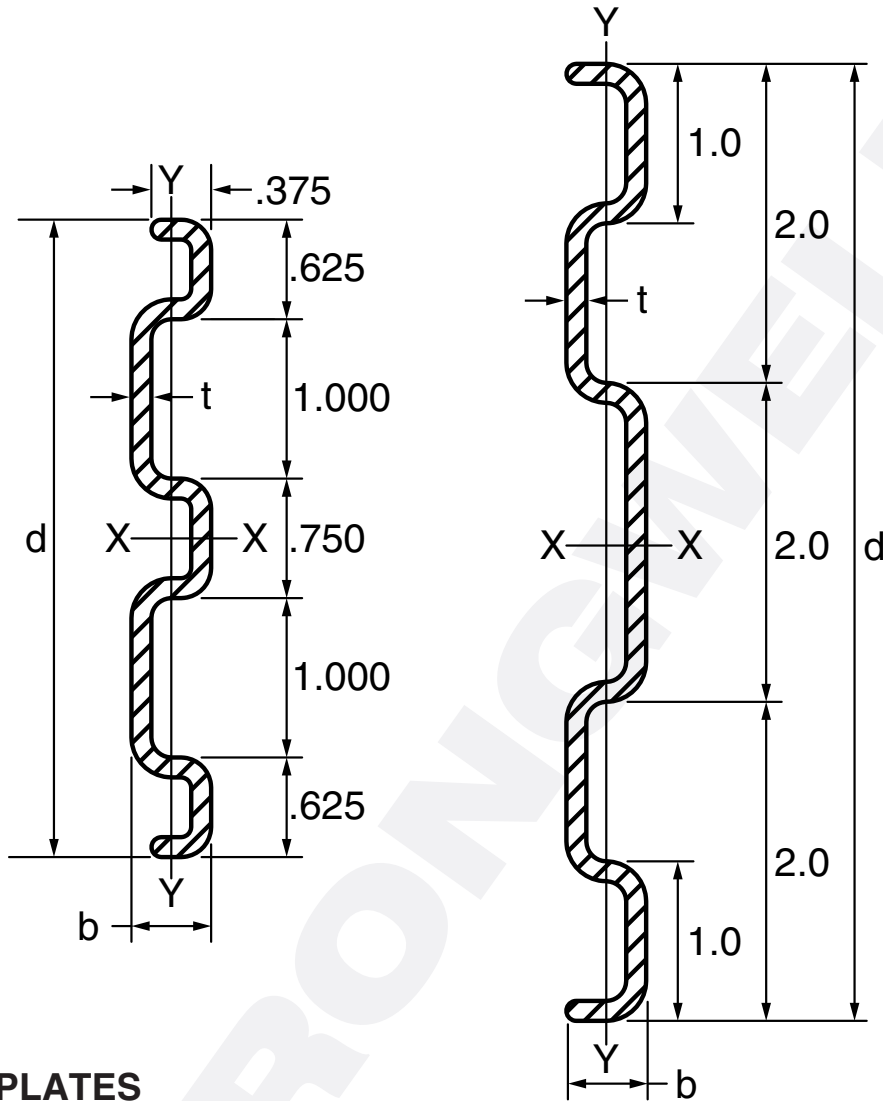

KICK PLATES

PHYSICAL PROPERTIES					SECTION PROPERTIES					
d	b	t	NOM. Wt/ft	A	AXIS X—X			AXIS Y—Y		
					I	S	r	I	S	r
in	in	in	lbs	in ²	in ⁴	in ³	in	in ⁴	in ³	in
4	1/2	1/8	0.52	0.666	0.966	0.483	1.204	0.017	0.064	0.161
6	1/2	1/8	0.73	0.927	3.127	1.042	1.836	0.026	0.094	0.167

SQUARE TUBE / ROUND HOLE

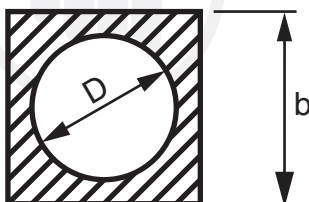

PHYSICAL PROPERTIES				SECTION PROPERTIES		
b	D	NOM. Wt/ft	A	I	S	r
in	in	lbs	in ²	in ⁴	in ³	in
1	3/4	.49	.558	.068	.136	.348

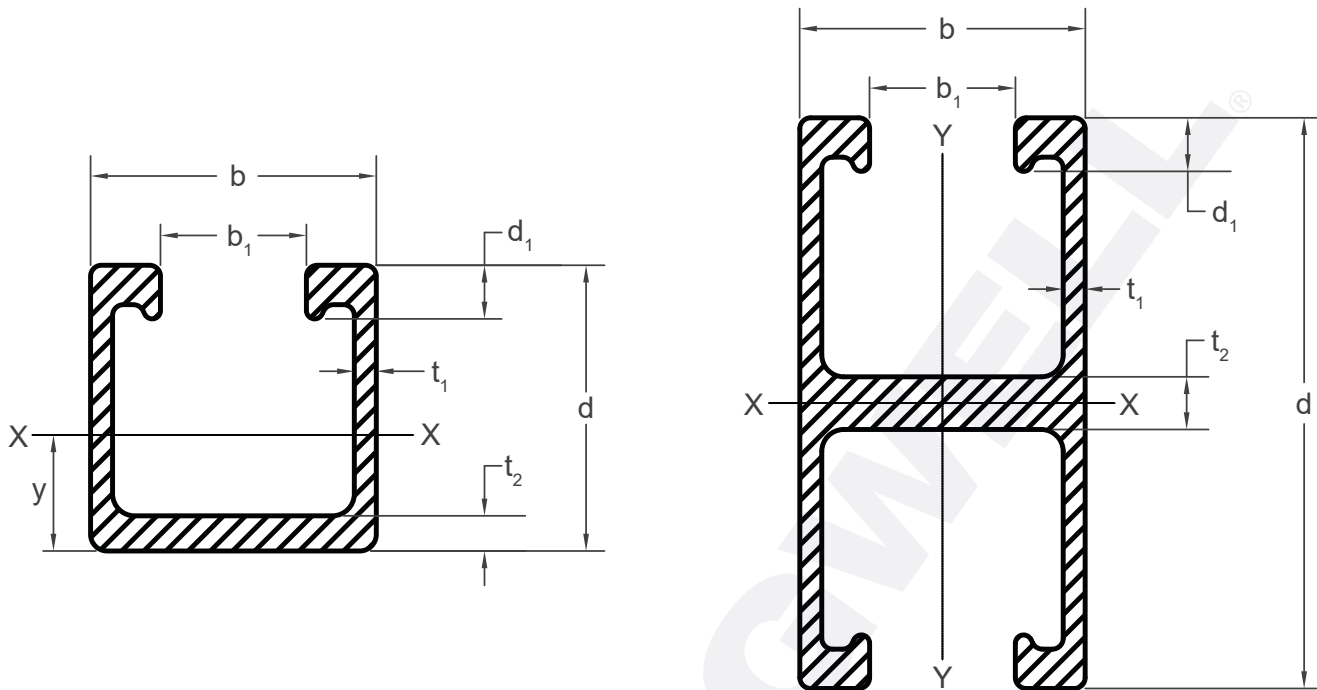

STRUTS (LEFT)

PHYSICAL PROPERTIES							SECTION PROPERTIES						DESIGN PROPERTIES
d	d ₁	b	b ₁	t ₁	t ₂	NOM. Wt/ft	AXIS X—X						J
							A	I	S _t	S _b	r	y	
in	in	in	in	in	in	lbs	in ²	in ⁴	in ³	in ³	in	in	in ⁴
1-5/8	9/32	1-5/8	7/8	5/32	5/32	0.65	0.680	0.232	0.258	0.322	0.584	0.722	0.004
1-5/8	0.305	1-5/8	0.830	1/8	0.200	0.68	0.819	0.280	0.298	0.409	0.584	0.684	0.009
1-1/32	0.305	1-5/8	0.830	1/8	0.200	0.51	0.610	0.082	0.140	0.184	0.366	0.446	0.006

DOUBLE STRUTS (RIGHT)

3-1/4	0.305	1-5/8	0.830	1/8	0.300	1.26	1.509	1.323	0.814	0.814	0.936	1.625	0.023
2-1/32	0.305	1-5/8	0.830	1/8	0.200	0.89	1.067	0.388	0.382	0.382	0.603	1.016	0.023

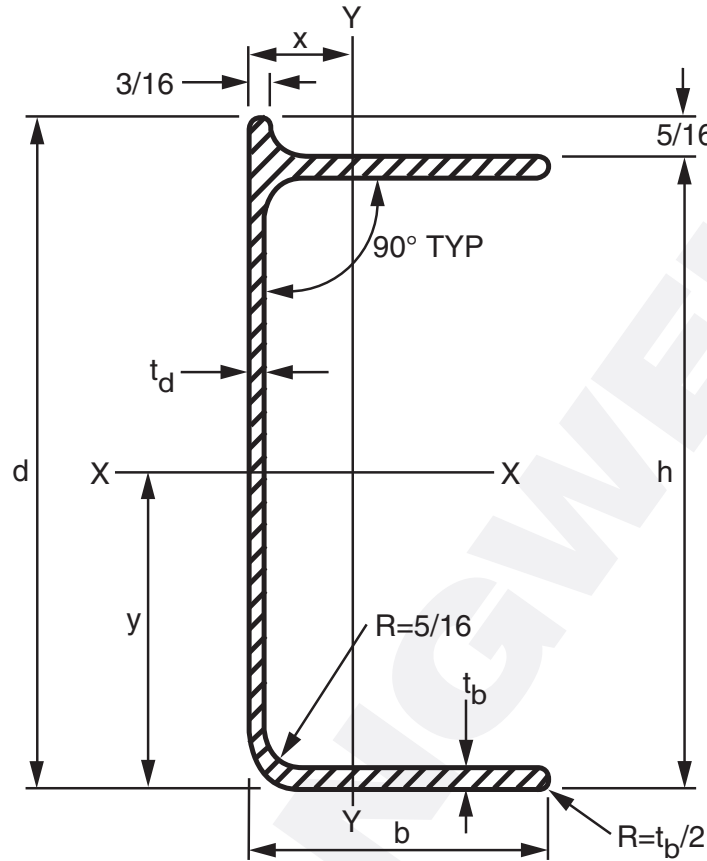

FLIGHT CHANNEL

PHYSICAL PROPERTIES							SECTION PROPERTIES									
h	d	b	t _d	t _b	NOM. Wt/ft	A	AXIS X—X					AXIS Y—Y				
							I	S _t	S _b	r	y	I	S _t	S _r	r	x
in	in	in	in	in	lbs	in ²	in ⁴	in ³	in ³	in	in	in ⁴	in ³	in ³	in	in
5-1/4	5-9/16	2-1/2	1/8	3/16	1.33	1.58	7.67	2.40	2.69	2.11	2.62	1.02	1.38	0.61	0.82	0.77
7-1/8	7-7/16	2-1/2	1/8	3/16	1.58	1.95	15.59	3.88	4.25	2.78	3.89	1.11	1.51	0.69	0.92	0.64

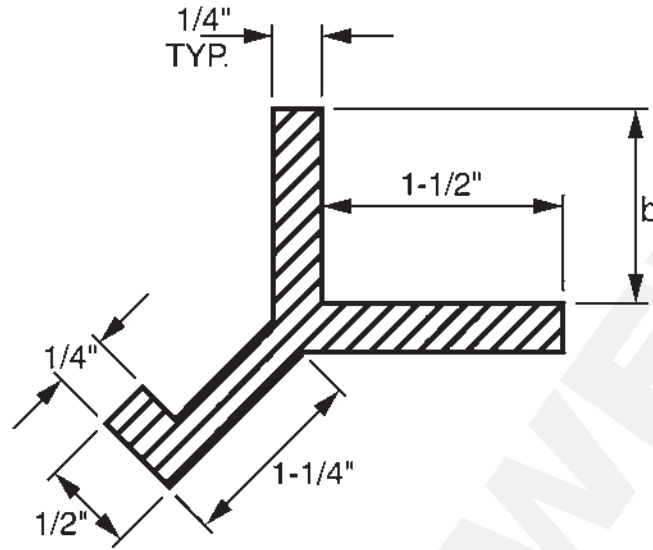

CURB ANGLES

PHYSICAL PROPERTIES			SECTION PROPERTIES									
b	NOM. Wt/ft	A	AXIS X—X					AXIS Y—Y				
			I	S _t	S _b	Y	r _x	I	S _t	S _b	X	r _x
in	lbs	in ²	in ⁴	in ³	in ³	in	in	in ⁴	in ³	in ³	in	in
1	.83	1.02	.275	.230	.288	1.01	.520	.548	.352	.573	.957	.733
1-1/2	.93	1.22	.512	.331	.443	1.16	.665	.559	.356	.592	.946	.676
2	1.31	1.36	.889	.473	.670	1.33	.809	.561	.473	.597	.941	.414

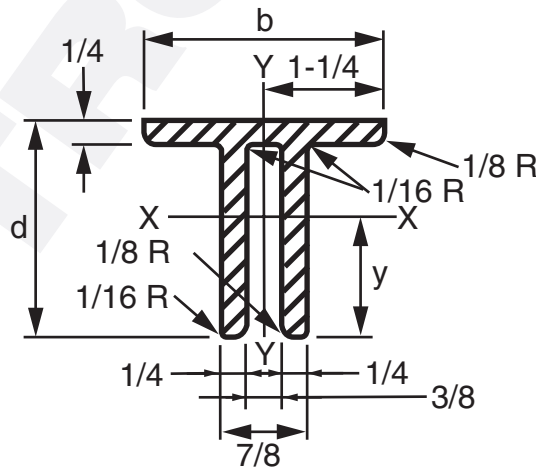

SLIDE GUIDE

PHYSICAL PROPERTIES					SECTION PROPERTIES							
b	d	t	NOM. Wt/ft	A	AXIS X—X					AXIS Y—Y		
					I	S _t	S _b	r	y	I	S	r
in	in	in	lbs	in ²	in ⁴	in ³	in ³	in	in	in ⁴	in ³	in
2-1/2	2-1/4	1/4	1.13	1.625	.823	1.01	.574	.712	1.43	.428	.343	.513

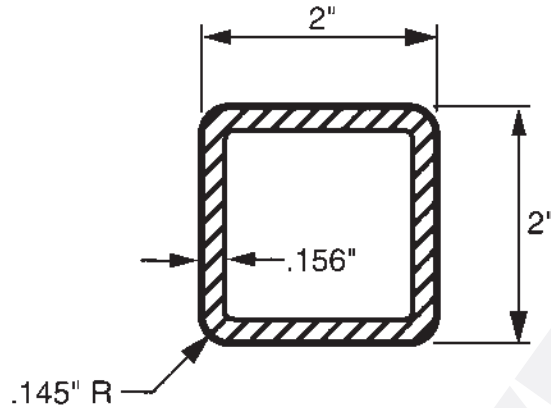

SAFRAIL™ SQUARE POST OR RAIL SECTION

PHYSICAL PROPERTIES		SECTION PROPERTIES				DESIGN PROPERTIES	
A	NOM. Wt/ft	I	S	r	A _w Z Webs	b — t	J
in ²	lbs	in ⁴	in ³	in	in ²		in ⁴
1.151	0.95	0.657	0.657	0.760	0.525	12.9	0.978

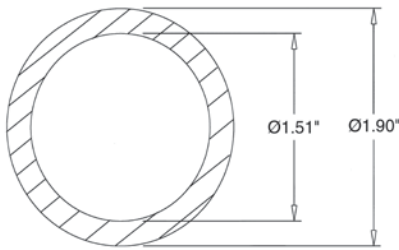

SAFRAIL™ ROUND POST OR RAIL SECTION

PHYSICAL PROPERTIES		SECTION PROPERTIES	
A	NOM. Wt/ft	I	S
in ²	lbs	in ⁴	in ³
1.05	0.86	0.385	0.405

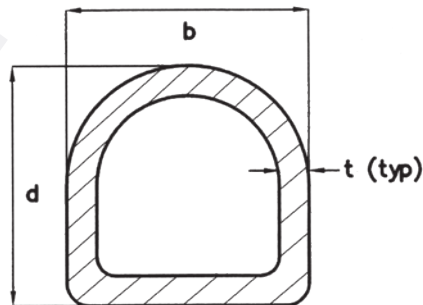

HALF ROUND RAIL SECTION

PHYSICAL PROPERTIES						SECTION PROPERTIES								
b	d	t	A	NOM. Wt/ft	\bar{y}	AXIS X—X					AXIS Y—Y			
						I	S _t	S _b	r	A _w	I	S	r	A _w
in	in	in ²	in ²	lbs	in ²	in ⁴	in ³	in ³	in	in	in ⁴	in ³	in	in
2	2	.25	1.51	1.23	.80	.76	.95	.63	.70	.63	.82	.82	.73	1.06